

SCAN COIN SC 303/313 Coin Counters

Service Manual

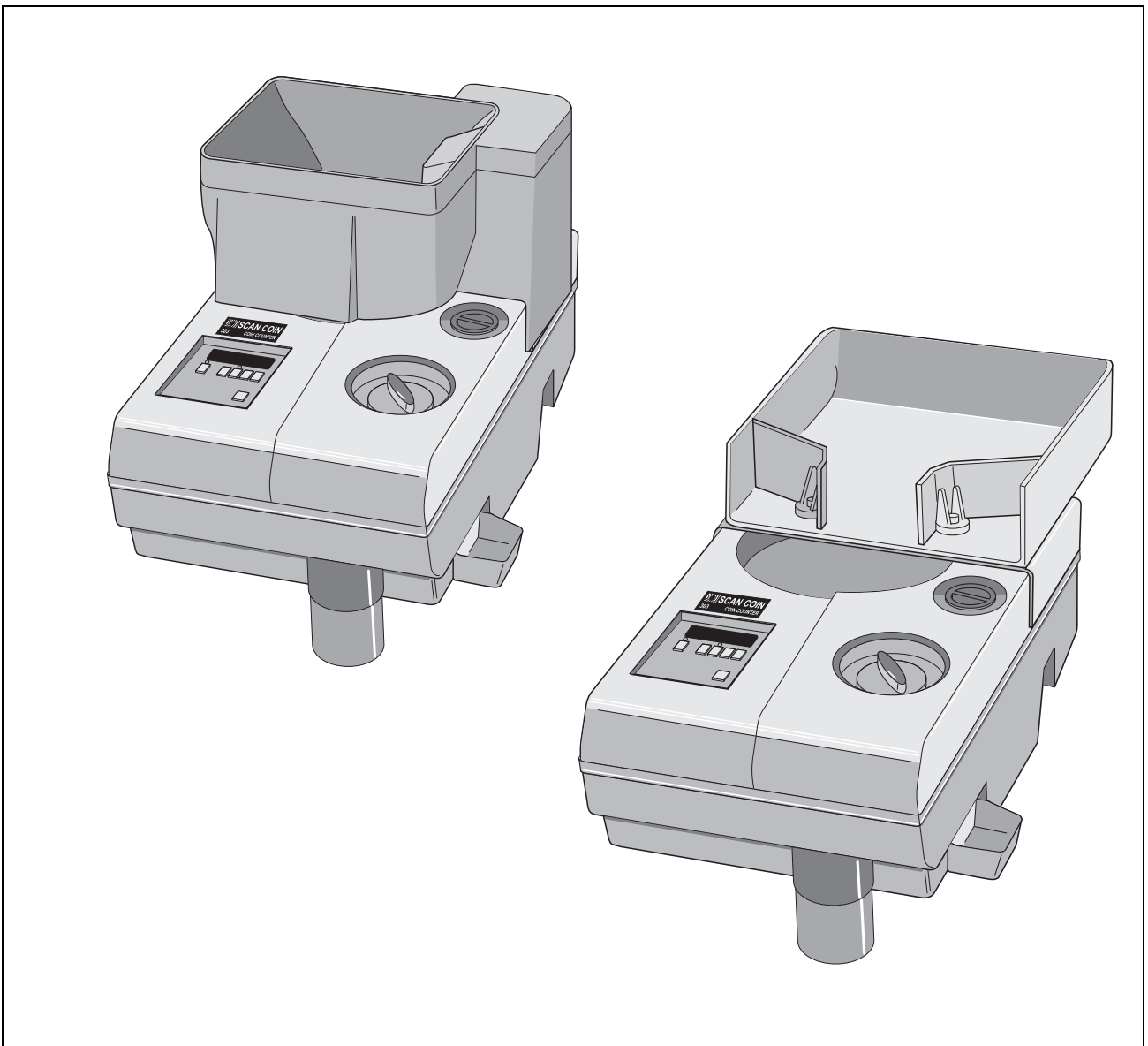

Contents

1	General Information	1
1.1	Declaration of Conformity.....	1
1.2	Environmental Compliance.....	1
1.3	Responsibility.....	1
1.4	About this Document.....	2
1.5	Revision History.....	2
1.6	Abbreviations/Acronyms.....	2
1.7	Related Documents.....	2
1.8	Software Version.....	2
2	Safety Precautions	3
2.1	Hazard Notices.....	3
2.2	Installation, Service and Maintenance.....	3
2.3	Operation.....	4
2.4	Warning Labels.....	4
3	Introduction	5
3.1	General.....	5
3.2	Controls.....	6
3.3	Positional References.....	6
3.4	Machine Label.....	6
3.5	Modes of Operation.....	6
3.6	Accessories.....	7
4	Installation	8
4.1	Installation Requirements.....	8
5	Technical Description	9
5.1	Mechanical Construction.....	9
5.2	Electronics.....	9
6	Technical Data	11
6.1	Physical.....	11
6.2	Environmental.....	11
6.3	Functional.....	11

7	Disassembly and Assembly	12
7.1	Exchanging Fuses	12
7.2	Plastic Covers	13
7.3	SC 313 Hopper Unit	14
7.4	Coin Disc.	15
7.5	Exchanging the Out-feed Belt	16
7.6	CPU Board	17
7.7	PSU Board	18
8	Periodic Maintenance	20
8.1	Cleaning	20
8.2	Mechanical Checks	20
9	Adjustments	21
9.1	Coin Disc.	21
9.2	Out-feed Belt	22
9.3	Channel Drive Belt	24
9.4	Coin Sensor	24
9.5	Master Reset	25
9.6	Program Version	25
10	Troubleshooting	26
10.1	Motor Stops	26
10.2	Removing a Coin Blocking the Coin Exit	26
10.3	Troubleshooting Table	26
11	Circuit Diagrams and Layouts	28
11.1	Electrical Interconnection Diagram	28
11.2	PSU Board Layout	30
11.3	PSU Board Circuit Diagram	32
11.4	CPU Board Layout	36
11.5	CPU Board Circuit Diagram	37
11.6	CH 45 Control PCB Layout	38
11.7	CH 45 Control PCB Circuit Diagram	39

>>>

>>>

12 Spare Parts.	40
12.1 Top Covers.	40
12.2 Bottom Cover Assembly	41
12.3 Motor Assembly	42
12.4 Main Plate Assembly.	43
12.5 Thickness Guide Block	44
12.6 Feed Mechanism Assembly.	45
12.7 Drive Assembly	46
12.8 Electronics.	47
12.9 SC 313 Hopper Unit	49

This page is intentionally left blank

1 General Information

SCAN COIN AB reserves the right to revise and improve its products as it sees fit. This publication describes the product at the time of publication and may not reflect the product at all times in the future.

This publication, or parts thereof, may not be reproduced in any form, by any method, for any purpose other than the purchaser's personal use, without the express permission of SCAN COIN AB, Sweden.

1.1 Declaration of Conformity

We, SCAN COIN AB, Malmö, Sweden, declare under our sole responsibility, that the product in this manual, to which this declaration relates, is in conformity with the following standards or other normative documents:

EN 60 950: 1992; EN 50 081-1: 1992; EN 50 082-1: 1992 following the provisions of Directive:

- Low Voltage Directive 73/23/EEC and amending Directive 93/68/EEC;
- EMC Directive 89/336/EEC and amending Directives 92/31/EEC and 93/68/EEC.

1.2 Environmental Compliance

Note! If the equipment contains batteries or accumulators, dispose of these separately according to local requirements.

WEEE Directive (valid in the EU only)

Waste Electrical and Electronic Equipment Directive 2002/96/EC.



Equipment marked with this symbol must be treated separately and in accordance with the local legislation that requires proper treatment of, recovery and recycling of used electric and electronic equipment.

Contact your SCAN COIN representative for further details.

1.3 Responsibility

The supplier of the equipment accepts no responsibility for injury or damage to personnel or equipment, if the equipment is altered in any way or used in a manner for which it was not intended at the time of delivery.

If the conditions for use of the equipment are changed, the supplier must be contacted or the declaration of conformity is invalidated.

1.4 About this Document

This technical handbook is valid for SC 303 and SC 313. It provides information required by qualified personnel to carry out repairs, maintenance and servicing.

Throughout this manual the instructions given apply to both machines unless otherwise stated.

1.5 Revision History

Revision	Major Changes
04	Added information about connector, CPU and PSU boards in the spare parts list see “12.8 Electronics” on page 47 . Updated spare parts list
03	Updated Spare parts list.
02	Corrections in spare parts list.
01	General review. New template. WEEE-directive.

1.6 Abbreviations/ Acronyms

Abbreviation	Description
AC	Alternating Current
CPU	Central Processing Unit
DC	Direct Current
ESD	Electrostatic Discharge
PSU	Power Supply Unit
SC	SCAN COIN

1.7 Related Documents

Document	Document number (Main number)
User's Guide	013264-000
Service Manual, including: <ul style="list-style-type: none"> • Technical Handbook • Spare Parts List 	This document

1.8 Software Version

This document describes machines with software versions up to and including version 4.03

2 Safety Precautions

2.1 Hazard Notices

This handbook contains hazard information which **must be regarded by all users**.

The hazard information is presented as a warning or a caution, as follows:



WARNING!

Warnings indicate a potential hazard to the health and safety of users. They clearly state the nature of the hazard and how to avoid it. They appear at their points of application in this handbook, but with different illustrations.

Caution!

Cautions indicate a potential hazard to the physical integrity of the machine, but not a danger to personnel. They clearly state the nature of the hazard and how to avoid it. They appear at their points of application in this handbook.

Note!

The servicing information and instructions contained in this technical handbook are for use by qualified personnel only. Any unauthorized attempt, by unqualified persons, to service or repair the machine, will nullify the equipment warranty.

2.2 Installation, Service and Maintenance



WARNING!

Risk of electric shock! High voltage inside the machine may be fatal for anyone in contact with it. Always switch OFF and disconnect the machine from mains supply before disassembling.

Caution!

Electrostatic discharge (ESD) may damage the electronic components. All electronic circuit boards in the machine are sensitive to ESD.

To prevent damage from ESD, **always** observe the following precautions:

- Always wear a suitably grounded wrist wrap – make it first on, last off.
- An unboxed or unbagged board is an unprotected board!
- Keep non-conducting materials (for example sleeves, ties, scarves) away from electrostatic safe work areas.

2.3 Operation



WARNING!
Risk of tipping!

The machine may fall over during bagging. Always make sure that the bag can rest on a shelf. Maximum weight to avoid tipping is 10 kg (22 lbs) for SC 303 and 20 kg (44 lbs) for SC 313.

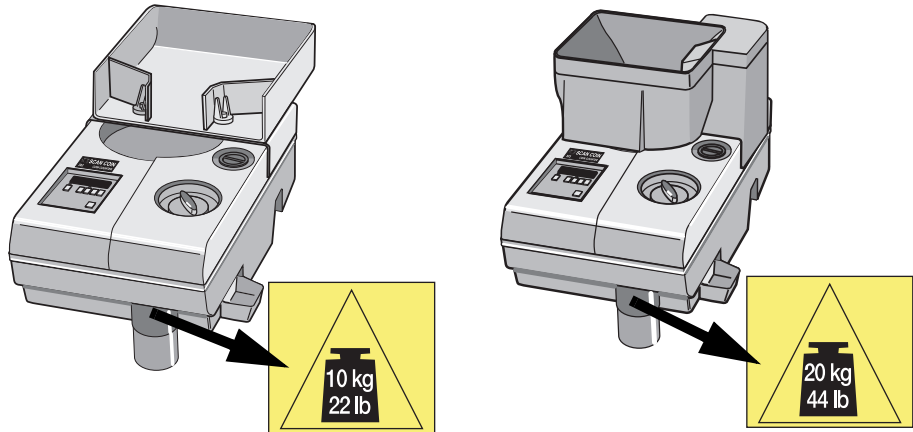

WARNING!
Risk of jamming!

This machine contains moving parts and sharp edges. Always be careful. Do not touch the components inside the machine while it is running.



WARNING!
Risk of impaired hearing.

Use ear protectors while the machine is running.

2.4 Warning Labels

The following warning labels are attached to the machine.



3 Introduction

3.1 General

The SC 303 and the SC 313 are virtually identical in appearance and operation.

The difference between the two models is that coins are fed into the SC 303 by means of a **tray** with the capacity to hold approximately 2,000 coins whereas coins are fed to the SC 313 by means of a **hopper** with a capacity of 3 litres which makes it easier to count high volumes of coins.

The machines can be programmed to count any coin or token with diameter in the range 14 to 34 mm (0.55 to 1.30") by means of two selector knobs - one for diameter (4) and one for thickness (3). Both machines are microprocessor controlled and all data is stored in non-volatile EEPROM so there is no need for battery back-up of the power supply.

Coins are loaded into a tray (SC 303) or hopper (SC 313) (6). When the **MOTOR ON/OFF** key is pressed, the coins are automatically fed from the hopper into the machine.

The number of coins counted by the machine is shown on a digital display (2) on the front panel. It is important to note that the display shows the number of coins counted - not the currency value of the coins.

Counted coins can be placed directly from the coin outlet (6) into collecting receptacles such as boxes, bags or tubes. Standard accessories are available to connect bags or tubes to the coin exit. Damaged or unidentified coins are sent to the reject tray (5).

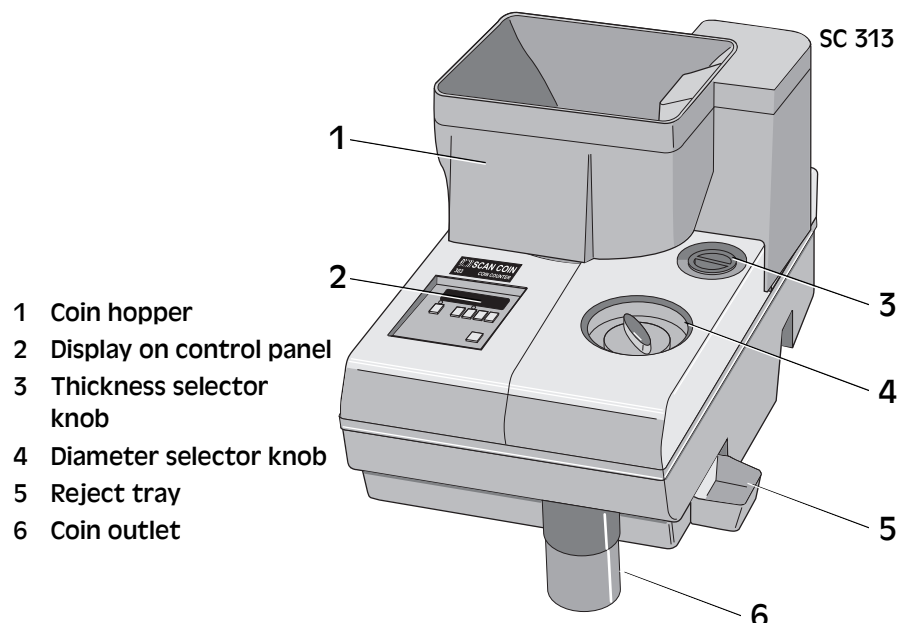

3.2 Controls

Refer to the *User's Guide*, see [“1.7 Related Documents” on page 2](#) for information.

3.3 Positional References

Unless stated otherwise, positions and directions such as left, right, upper, lower, rear, clockwise and counter-clockwise are given with respect to the machine when viewed from the front.

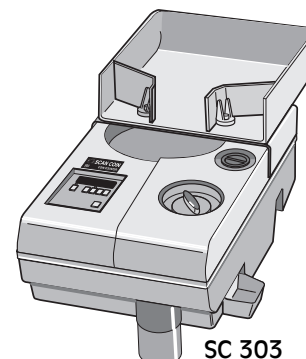

3.4 Machine Label

The label below is an **example** of information available on the machine.

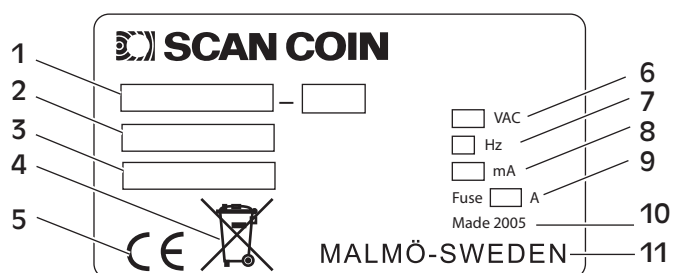

- | | |
|----------------|------------------------|
| 1 Machine type | 6 Supply voltage |
| 2 Part No. | 7 Frequency |
| 3 Serial No. | 8 Currency consumption |
| 4 WEEE-symbol* | 9 Fuse |
| 5 CE-symbol | 10 Year of manufacture |

3.5 Modes of Operation

Refer to the *User's Guide*, see [“1.7 Related Documents” on page 2](#) for information.

3.6 Accessories

All electrical accessories are plugged into sockets on the back of the machine.

Accessory	Description	Remark
BA 3 011611-000	Bagging attachment	Bag holder replacing the coin cup on the right hand side of the machine.
BG 1 010686-000	Bag guide without shelf	Mounted on the coin outlet. For small paper bags and plastic bags.
BCS 1 002959-000	Bag guide with shelf	Same as BG 1 but with a shelf for the bag to rest on.
CA 1 011612-000	Coin adaptor	To enable TI 1, BG 1, BGS 1 to fit the machine.
HE 1 013501-000	Hopper extension kit	SC 313 only. Increases the hopper capacity to approx 4.8 litres.
IH 1 002525-000	Insert holder	Holder for tubing insert (TI 1). Mounted on the machine's coin outlet.
TI 1 002703-xxx	Tubing insert	Various sizes depending on coin diameter. Used with IH 1.

4 Installation

4.1 Installation Requirements

- The machine must be placed on a stable horizontal surface.
- Ensure that the environmental requirements are met when installing the machine, see [6.2 “Environmental” on page 11](#).
- Do not place the machine close to any radiators.
- Do not place the machine in direct sunlight as reflections from the sunlight will make it impossible to read messages displayed on the screen and may also cause the internal temperature of the machine to rise above an acceptable level.
- Allow some free space around the machine to enable the air to circulate.

**WARNING!****Risk of electric shock!**

The machine is of metal construction and must therefore always be earthed to the supply. Ensure that the plug on the supply lead is earthed and that the supply source is earthed. This is a requirement for this type of equipment and if not adhered to will contravene the international standards of Health and Safety in the work place.

Although this machine has been tested for electromagnetic compatibility and vibration characteristics, it is recommended that no equipment which generates a high level of electromagnetic interference (EMI) or vibration is placed close to this machine.

Note! If the plug on the supply lead to the machine has a fuse, make sure it has the correct rating in amps. Refer to [6.2 “Environmental” on page 11](#).

For AC voltage input, see section [6.2 “Environmental” on page 11](#).

5 Technical Description

5.1 Mechanical Construction

The SC 303/SC 313 consist of a chassis enclosed within removable plastic covers. With the covers removed all components of the machine are accessible for maintenance.

The drives for the out-feed belt, the coin disc, and the channel drive belt are powered by the main electric motor.

5.2 Electronics

The electronics in the SC 303 and SC 313 are contained on the CPU board and the PSU board.

CPU Board

The functions of the CPU board are based on a single microchip controller. The supply voltage is + 5 V DC and the power consumption is approximately 180 mA.

Power Fail and Watch Dog

A power fail and watchdog circuit monitors the unregulated 24 V DC supply. The watch dog is connected via CN2 pin 8 to IC8 pin 4.

If the voltage drops to approximately 14 V, power fail is detected at pin 12 of the microcontroller. The program is interrupted and data is transferred to the EEPROM. At the next power on, the information written into the EEPROM is read into the microcontroller memory.

Display

There are six multiplexed, seven segment LEDs (DIS1 - DIS6) mounted on the CPU board. Ports P00 to P07 on the microcontroller drive the display segments and port P27 together with IC3 select the digits. Each of the six display units is lit for approximately 270 μ s, which gives a cycle time of approximately 1.7 ms. To avoid display flicker the display units are updated in the order DIS5, DIS2, DIS6, DIS1, DIS3, DIS4, DIS5 and so on.

Keys

All control keys are connected directly to the microcontroller via the ports P10 to P15. All contact bounces are filtered by the software.

Count Sensor Input

Signal pulses from the coin sensor are processed by the microcontroller. Any pulses with a duration shorter than 1 ms are rejected as false.

Permanent Memory

IC5 is a serial EEPROM which forms the permanent memory. In the event of a power supply loss the micro controller automatically stores important information at this location. When the power supply is resumed the micro controller reads the information from the EEPROM and restores the machine to the state it held prior to the power loss.

PSU Board

The PSU board uses a 5 V/1 A switched regulator. A 6.8 V transient absorption diode Z1 protects the circuit from transient voltages.

The motor is switched ON/OFF via opto-isolator OP1 and triac SCR1. A single 5 V pulse is used for the switching. Forward/reverse control of the motor is provided by means of the 24 V relay REL1.

The relay switches the motor supply voltage between two independent windings on the motor, connected in opposite polarity. The stop solenoid is operated via the transistor T1. This paragraph relates to revisions 1, 2 and 3.

On revision 4 the motor is controlled by triacs only, instead of a relay. The coin level detection is integrated on the PSU board, so there is no need to use the CH 45 board.

6 Technical Data

6.1 Physical

Description	SC 303	SC 313
Coin tray, approximately	2.0 litres	3.0 litres
Width	228 mm (9.0")	260 mm (10.3")
Height	165 mm (6.5")	310 mm (12.2")
Depth	325 mm (12.8")	380 mm (15.0")
Weight	7.5 kg (16.5 lbs)	10.5 kg (23.0 lbs)

6.2 Environmental

Description	Value	
Operating temperature	15-35 °C	
Operating humidity	30-80% R.H.	
Noise level (operation)	81 dB (A)	
Power requirements:		
• Voltage	220-240 VAC	110-130 VAC
• Frequency	50 Hz	60 Hz
• Consumption	800 mA	400 mA

6.3 Functional

Description	Value
Counting rate, maximum	2,700 coins/minute Coins with 15 mm (0.6") diamete
Coin diameter range	14.0-34.0 mm (0.55"-1.30")
Coin thickness range	1.0-3.4 mm (0.04"-0.13")
Display	6 digit
Batch range	5-10,999

7 Disassembly and Assembly



WARNING!
Risk of electric shock!
 Follow the Safety Precautions.

Note! Some screws have nuts and/or washers. Be careful not to lose them when removing the screws.

Note! Assembly is the reverse of disassembly, if not stated otherwise.

7.1 Exchanging Fuses

- a) Switch off the mains electrical supply and disconnect the lead from the supply socket.
- b) Remove the fuse holder box (1) from the rear of the machine by simultaneously pressing in the securing side clips.

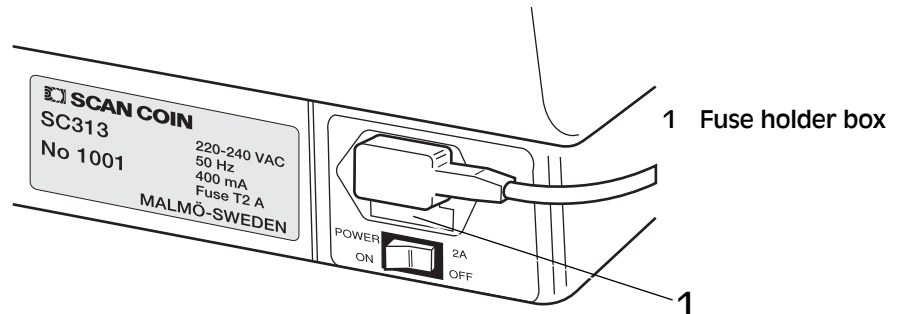

- c) Exchange both fuses for ones with the same voltage and current rating as those already fitted (T2 A).

Caution! Use only fuses of the same current and voltage rating as those originally fitted. The use of incorrect fuses could result in damage to the machine.

- d) Replace the fuse holder box and press it firmly in place.

Note! There is also a 1 A fuse on the PSU board in the 24 V AC input to the board from the transformer. Refer to [“7.2 Plastic Covers” on page 13](#) and [“7.7 PSU Board” on page 18](#) for details of how to gain access to the PSU board.

7.2 Plastic Covers

To gain access to the main body of the machine for adjustment or exchange of parts the plastic covers must be removed.

- a) Remove the plastic cover (2) from the right hand side of the machine.
- b) Loosen and remove the screw on the right near the sensor and then lift off the top left plastic cover (1).

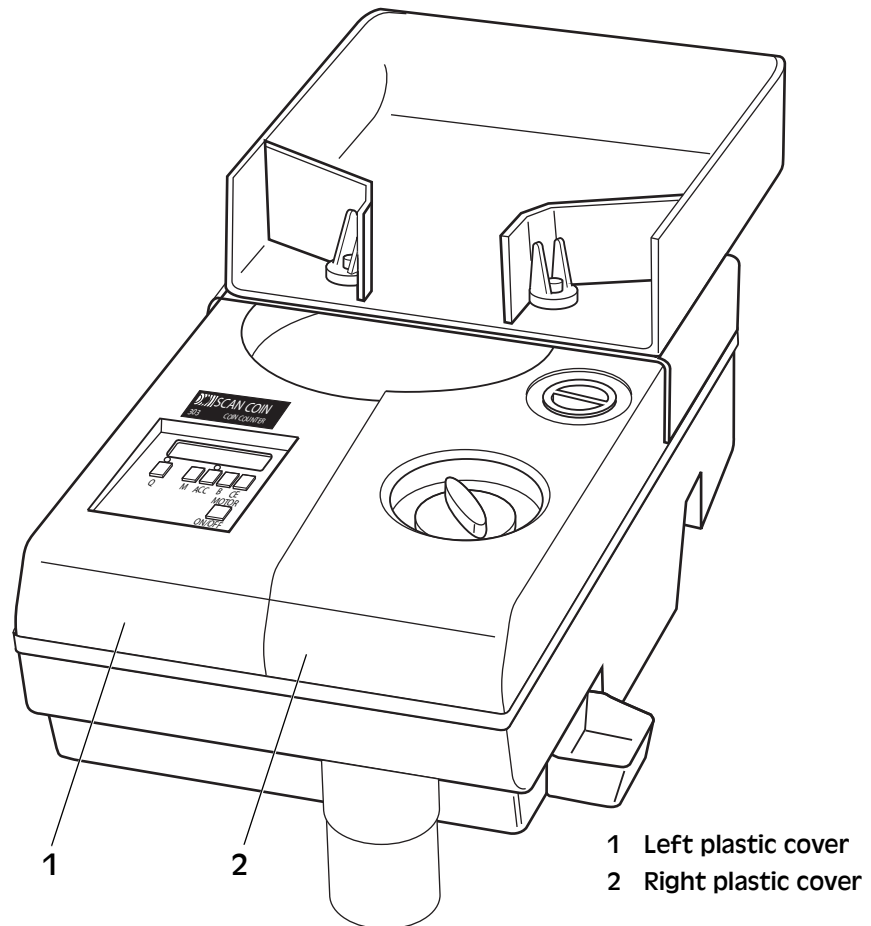

- c) Loosen and remove the two screws securing the top coin tray and top back cover.
- d) Lift off the coin tray and top back cover.
- e) Carefully turn the machine upside down.
- f) Loosen and remove the four fixing screws securing the lower cover to the main body.
- g) Carefully turn the machine back the right way up.
- h) Unplug the power connector located at the motor assembly.
- i) Lift the main body out of the lower cover.

7.3 SC 313 Hopper Unit

To gain access to the interior of the hopper unit (1):

- a) Loosen and remove the four screws in the metal plate on the underside of the hopper.
- b) Lift off the hopper cover.

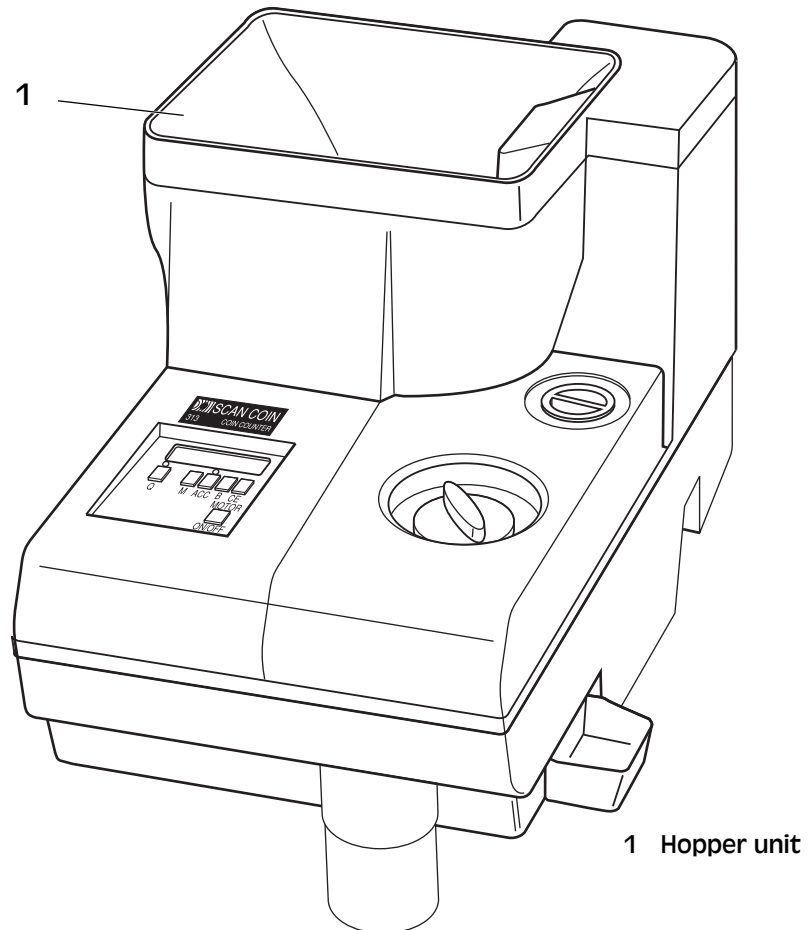

7.4 Coin Disc

- a) Remove the coin tray/coin hopper unit, see [“7.3 SC 313 Hopper Unit” on page 14](#).
- b) Loosen and remove the top screw (1).
- c) Lift off the cone (2).
- d) Loosen and remove the locking nut (3).
- e) Lift off the coin disc (4).

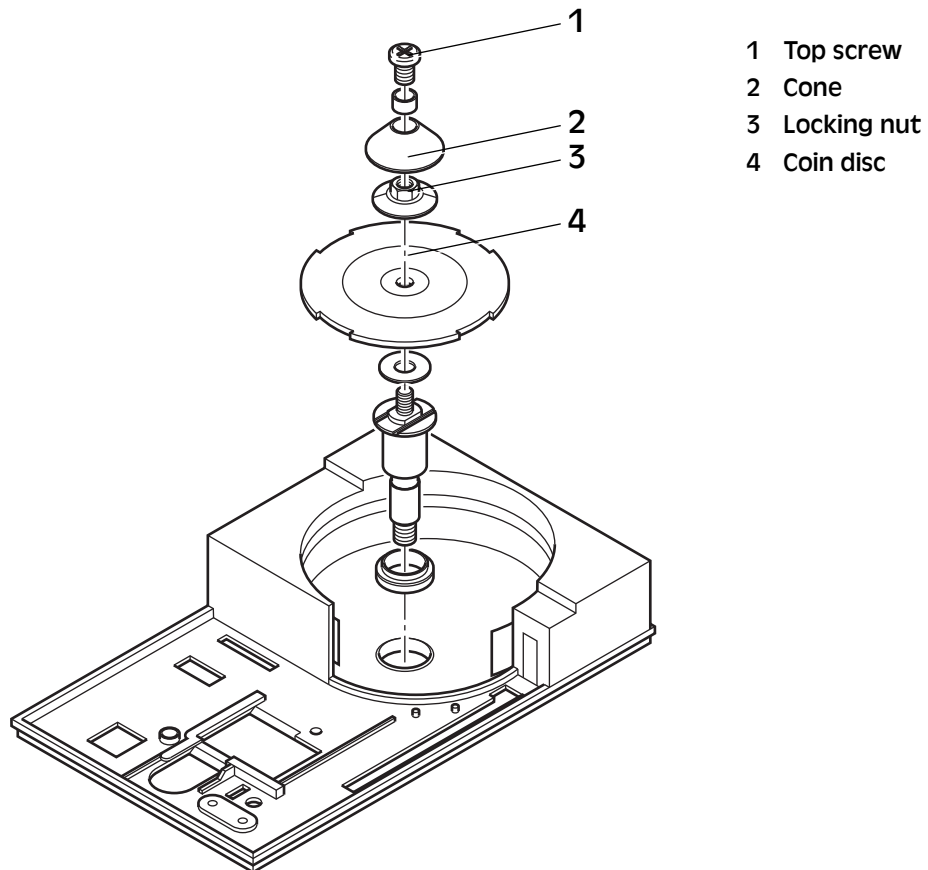

7.5 Exchanging the Out-feed Belt

It is recommended that the out-feed belt is replaced after approximately 1 million coins have been counted.

- a) Set the coin diameter knob to minimum.
- b) Remove the right hand plastic cover.
- c) Raise the out-feed belt (1).
- d) Lift the feed mechanism.
- e) Remove the old out-feed belt and exchange it for a new one.
- f) Replace the feed mechanism and out-feed belt.
- g) Replace the right hand plastic cover.

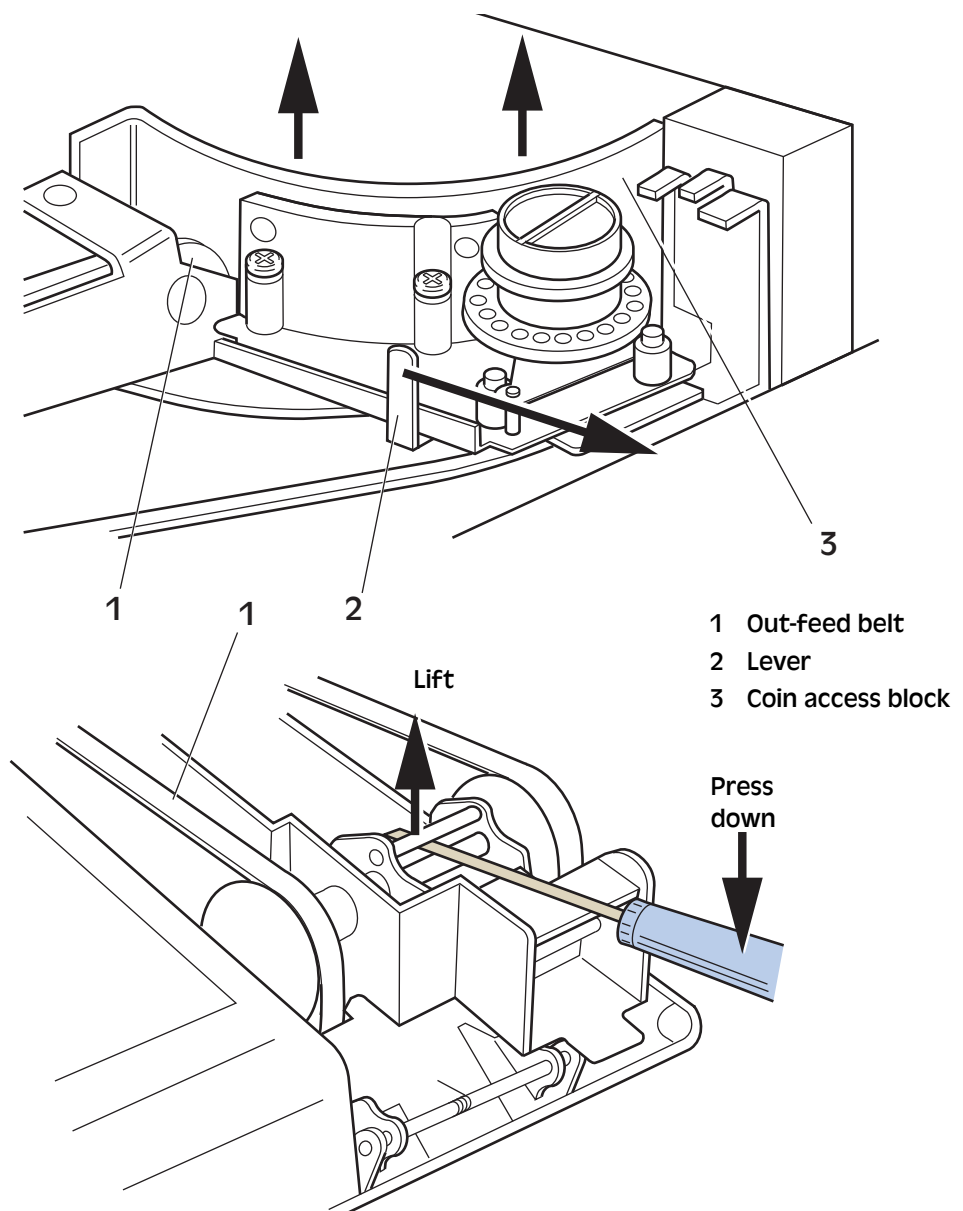

7.6 CPU Board

- a) Remove the plastic covers, see [“7.2 Plastic Covers” on page 13.](#)
- b) Disconnect connectors CN1 and CN2 from the CPU board.
- c) Loosen and remove the four CPU board fixing screws.
- d) Lift the CPU board out of the machine.

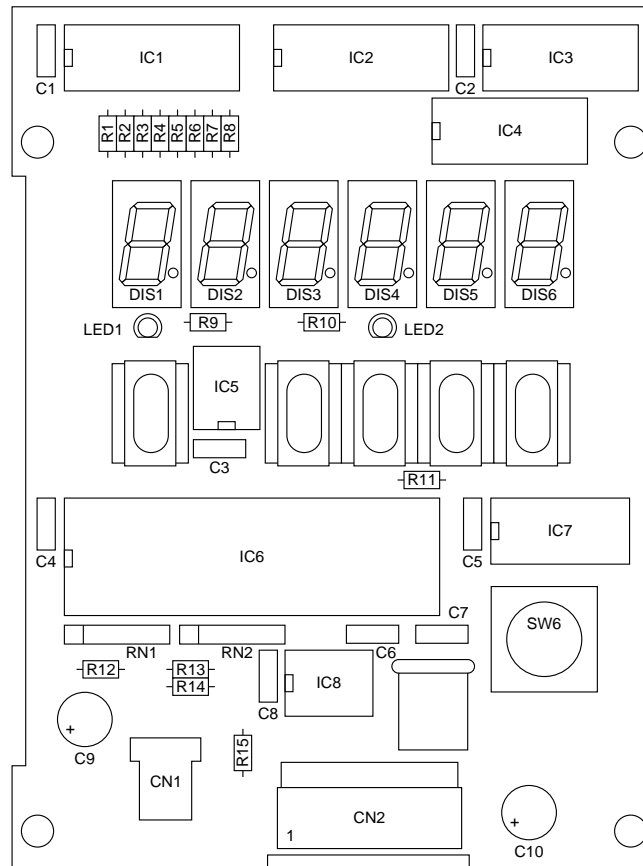

7.7 PSU Board

Note! If a PSU board is replaced it should always be replaced with one having the same or higher revision number. A revision 4 board can replace any older board. If you order a replacement PSU board you will automatically receive a revision 4 board.

- a) Remove the plastic covers, see [“7.2 Plastic Covers” on page 13.](#)
- b) Remove the CPU board, see [“7.6 CPU Board” on page 17.](#)
- c) Disconnect connectors CN1, CN2, CN3, CN4, CN5 and CN6 from the power supply board.

On SC 313 also disconnect CN7 and CN8.

- d) Lift the power supply board out of the machine.

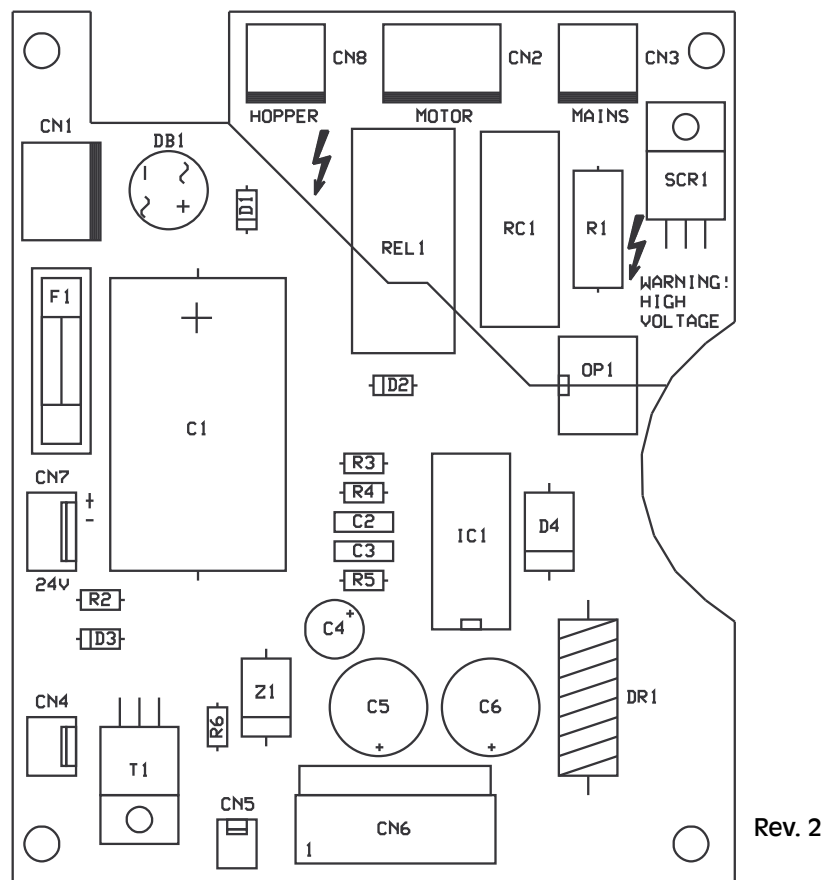

>>>

>>>

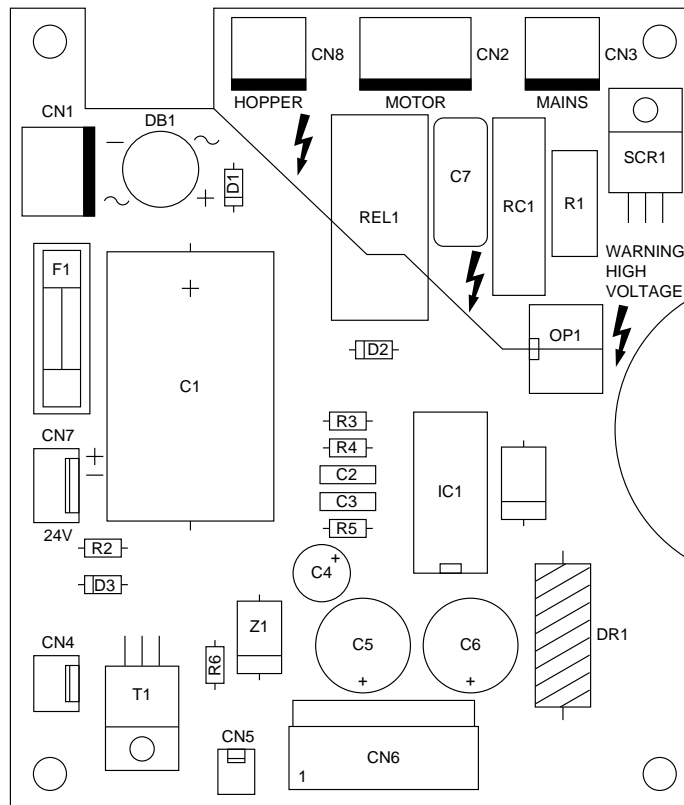

Rev. 3

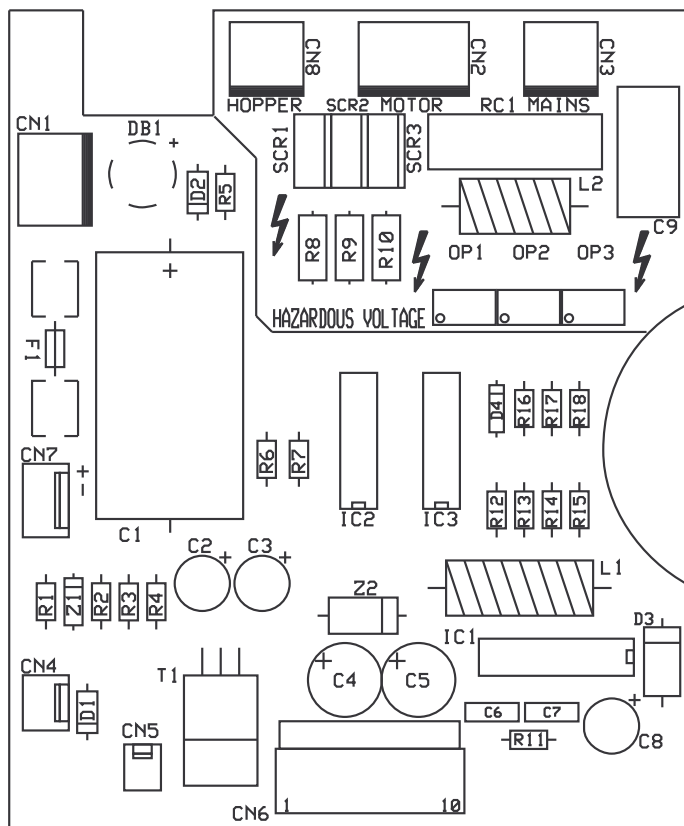

Rev. 4

8 Periodic Maintenance



WARNING!
Risk of electroshock!
Follow the Safety Precautions!

Caution! Do not attempt to oil or lubricate any parts in the machine. All bearings are pre-lubricated and will be damaged if any lubricant is added.

8.1 Cleaning

The machine should be cleaned daily to prevent a build-up of dirt which might affect the operation of the machine. Refer to the User's Guide.

8.2 Mechanical Checks

- a) Check that all belts are set to the correct tensions, see ["9 Adjustments" on page 21](#).
- b) Check the diameter and thickness settings.
- c) Ensure that the maximum and minimum diameters and thicknesses can be selected.

9 Adjustments



WARNING!
Risk of electroshock!
 Follow the Safety Precautions!

To gain access to the components inside, remove the plastic covers, see [“7.2 Plastic Covers” on page 13](#).

9.1 Coin Disc

The coin disc must be set at the same level as or 0.1 mm (0.004") above the coin rail plate. If the disc is lower than the plate the coin flow and counting speed will be reduced. If necessary remove the coin disc and place thin washers, available as spare parts, below the disc on the shaft to achieve the required level.

- 1) Loosen and remove the top screw (1).
- 2) Lift off the cone (2).
- 3) Loosen and remove the locking nut (3).
- 4) Lift off the coin disc (4).
- 5) Add or remove washers (5) from the shaft (6) as required.
- 6) Assemble in the reverse order and tighten the top screw.

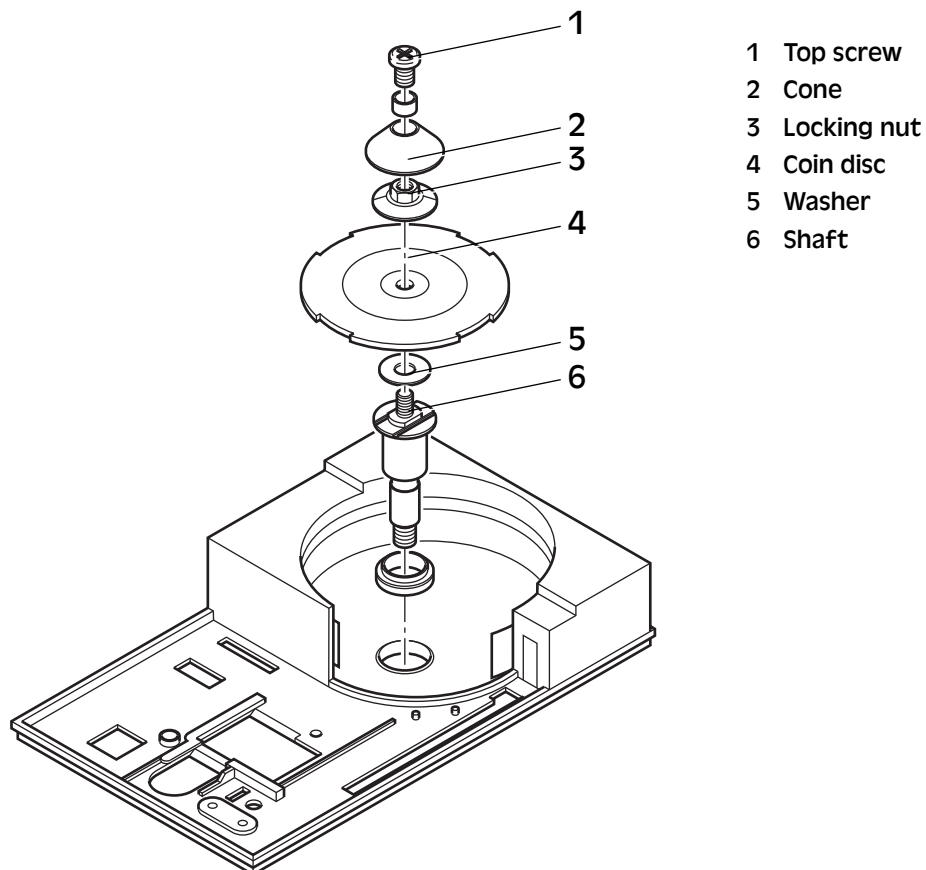

9.2 Out-feed Belt

Before making any adjustments to the out-feed belt, ensure that the belt is clean and is not worn.

Tension Adjustment

The belt tension can be set by adjusting the position of the front pulley. The spring loaded feed arm keeps a downward pressure on the belt to prevent coins from slipping.

- a) Loosen the nut at the front pulley.
- b) Adjust the position of the front pulley to provide the correct belt tension.
- c) Tighten the nut at the front pulley.

Caution! Do not over tighten the belt as it may cause damage and slow the speed of the machine.

It is recommended that after adjusting the belt the level adjustment is checked as described below.

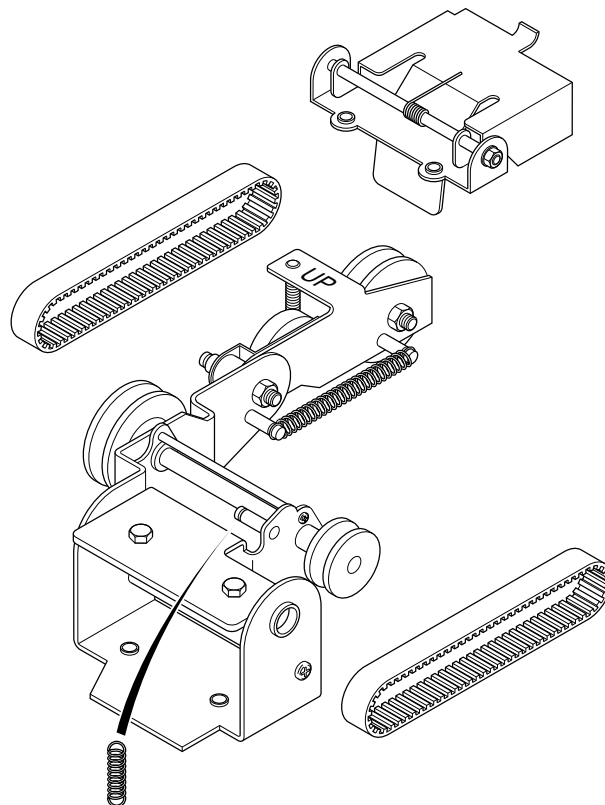

Level Adjustment

The feeding belt must be set to a position that allows maximum speed of movement of the coins across the sensor without slippage.

This is achieved by adjusting the height of the belt with respect to the thinnest coin that the SC 303/SC 313 is likely to count.

The feeding belt should be lowered to a position that allows for maximum speed across the sensor without belt slip. As the level of belt is equal for thick or thin coins, always use the thinnest coin (normally the smallest) when adjusting the belt level.

The level is set by means of two adjustment screws (1). Normally the belt should be about 0.5 mm (0.02") lower than the thinnest coin.

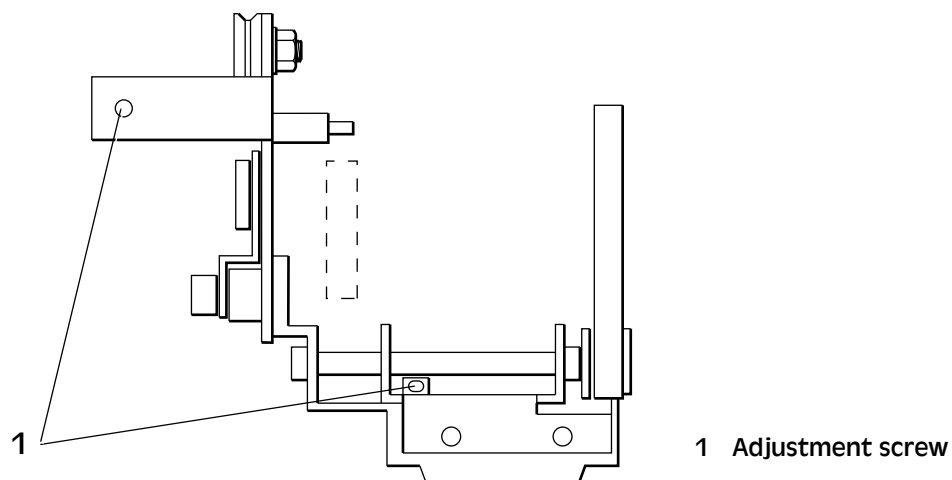

- Place the thinnest coin on the coin track below the belt.
- Using a thickness gauge, measure the gap between the coin and the feed belt.
- Loosen the locking nut on each adjustment screw.
- Adjust the position of the screws until the belt is at the required height.
- Tighten the locking nut on each adjustment screw.

An alternative method of setting the belt level is as follows:

- Raise the belt by turning the screws clockwise until the coins slip under the belt.
- Run some coins through the machine.
All the coins should slip under the belt.
- Lower the belt by turning the screws anticlockwise until the coins will just feed under the belt.
- Turn each screw half a turn clockwise.
- Tighten the locking nut on each adjustment screw.

9.3 Channel Drive Belt

If the channel drive belt (1) tension is too tight it will prevent the feed mechanism from working properly.

- a) Check the tension of the channel drive belt.
- b) If necessary, select a different position for the intermediate wheel (2).

Six different positions can be selected.

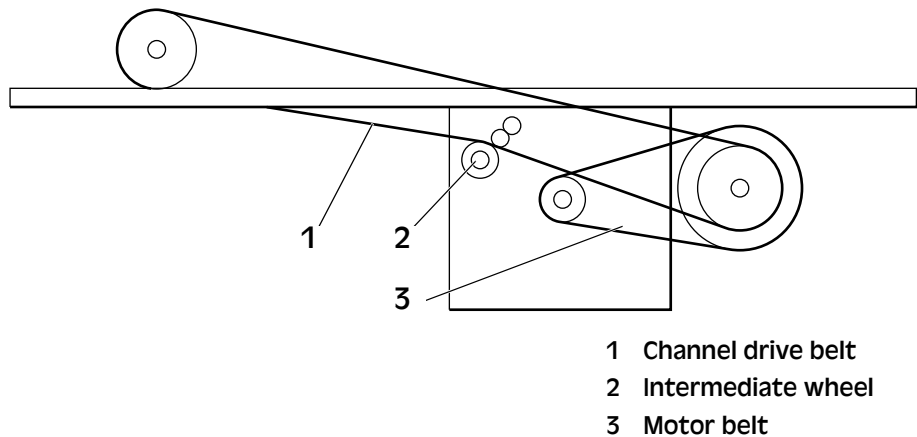

9.4 Coin Sensor

The sensor should be adjusted to give a pulse width of 8 to 10 ms when a 15 mm (0.6") diameter coin passes.

- a) Attach the probe leads of an oscilloscope to pins 2 and 3 of connector CN1 on the CPU board.
- b) Feed a 15 mm (0.6") diameter coin through the machine and inspect the pulsewidth obtained.
- c) The sensor is attached to the solenoid bracket on the underside of the chassis.

Adjust the position of the sensor by moving the complete solenoid unit.

Note! It is not normally necessary to measure the pulse length after replacing the sensor. It is sufficient just to adjust the sensor as close as possible to the drive pulley without actually touching it.

9.5 Master Reset

The master reset option is available in software version 2 and onwards. When this option is selected:

- All registers are set to zero.
 - Automatic stopping is enabled.
 - The fixed batch stop quantities are set to their default values (20, 25, 40, 50, 100, 500 and 1000).
- a) Simultaneously press the **Q**, **M**, **B** and **MOTOR ON/OFF** keys while setting the mains ON/OFF switch to **On**.
 - b) When the display changes from a row of “8”s to a blank display, release the **Q**, **M**, **B** and **MOTOR ON/OFF** keys.
 - c) Press and hold the **C** key.
The message “r E S A L L” is displayed.
 - d) Release the **C** key. The display shows a row of “8”s and then the message “r E S E E”.

9.6 Program Version

To see the current program version, press **Q** and **M** and switch **On**.

10 Troubleshooting

10.1 Motor Stops

The motor has an automatic thermal cut-off function which is activated when the motor winding overheats ($140^{\circ}\text{C} \pm 5\%$). If this happens, the machine will take around 15 - 20 minutes (depending on room temperature) to cool to below 132°C and restart. To allow it to do so, turn **Off** the machine at the mains.

If the machine repeatedly cuts out exchange the motor for a new one.

10.2 Removing a Coin Blocking the Coin Exit

This instruction should only be followed after clearing a blocked coin exit, see the *User's Guide*, been completed.

- a) Switch off the mains electrical supply and disconnect the mains lead from the supply socket.
- b) Remove the top covers from the machine.
- c) Remove the thickness guide block.
- d) Remove the coin blocking the coin exit.
- e) Replace the thickness guide block and push it firmly in place.
- f) Replace the top covers on the machine.

10.3 Troubleshooting Table

Fault/Error	Cause	Action
Machine does not start No display function	1. Mains cable.	Check mains cable.
	2. Fuse blown.	Check mains fuse at mains socket. Check fuse on the PSU. Check PSU board connectors.
	3. +5 V missing.	Check +5 V DC on CPU CN2, pin 1 to negative.
	4. PSU.	Exchange board.
	5. CPU.	Exchange board.
Fixed bag stops can be selected	1. Unprogrammed.	See operating instructions on how to program fixed stops or perform a Master reset , see "9.5 Master Reset" on page 25.
Hopper motor does not stop automatically	1. Unprogrammed.	See operating instructions on how to program after finished counting or perform Master reset , see "9.5 Master Reset" on page 25.
	2. Old version of PSU in new machine.	Exchange board.

Fault/Error	Cause	Action
Motor does not start	1. + 24 V DC missing.	Check +24 V DC on CPU CN2, pin 8 to negative.
	2. Relay or triac on PSU board is defective.	Exchange board, see “7.7 PSU Board” on page 18.
	3. Bad connection.	Check CN2 connector.
	4. Start switch.	Exchange switch or CPU, see “7.6 CPU Board” on page 17.
	5. Motor is defective.	Exchange motor.
Motor starts but reverses	1. Relay on PSU board.	Exchange board, “7.7 PSU Board” on page 18.
Motor starts but no count on display	1. Sensor defective or badly adjusted.	See “9.4 Coin Sensor” on page 24.
	2. CPU defective.	Exchange CPU board, see “7.6 CPU Board” on page 17.
Overcounts in batch mode	1. Solenoid.	Check CN4 on PSU, exchange solenoid.
Undercounts in the first batch	1. Operator failure.	Last batch from previous count was not even. Reset register “B”.
Low counting speed	1. Adjustments.	Check coin disc adjustment. Check out-feed belt adjustment. Check thickness block adjustment.
Coin jamming at coin disc or thickness guide block	1. Adjustments.	Check adjustments on thickness guide block parallel with coin disc.
Coin jamming at the coin rail	1. Adjustments.	Check for proper diameter adjustment.
	2. Worn rails.	Exchange left and right sorting rails.
Undercounts, especially on smaller coins	1. The sensor is too far away from the pulley.	See “9.4 Coin Sensor” on page 24.

11 Circuit Diagrams and Layouts

11.1 Electrical Interconnection Diagram

PSU board rev. 2 and 3

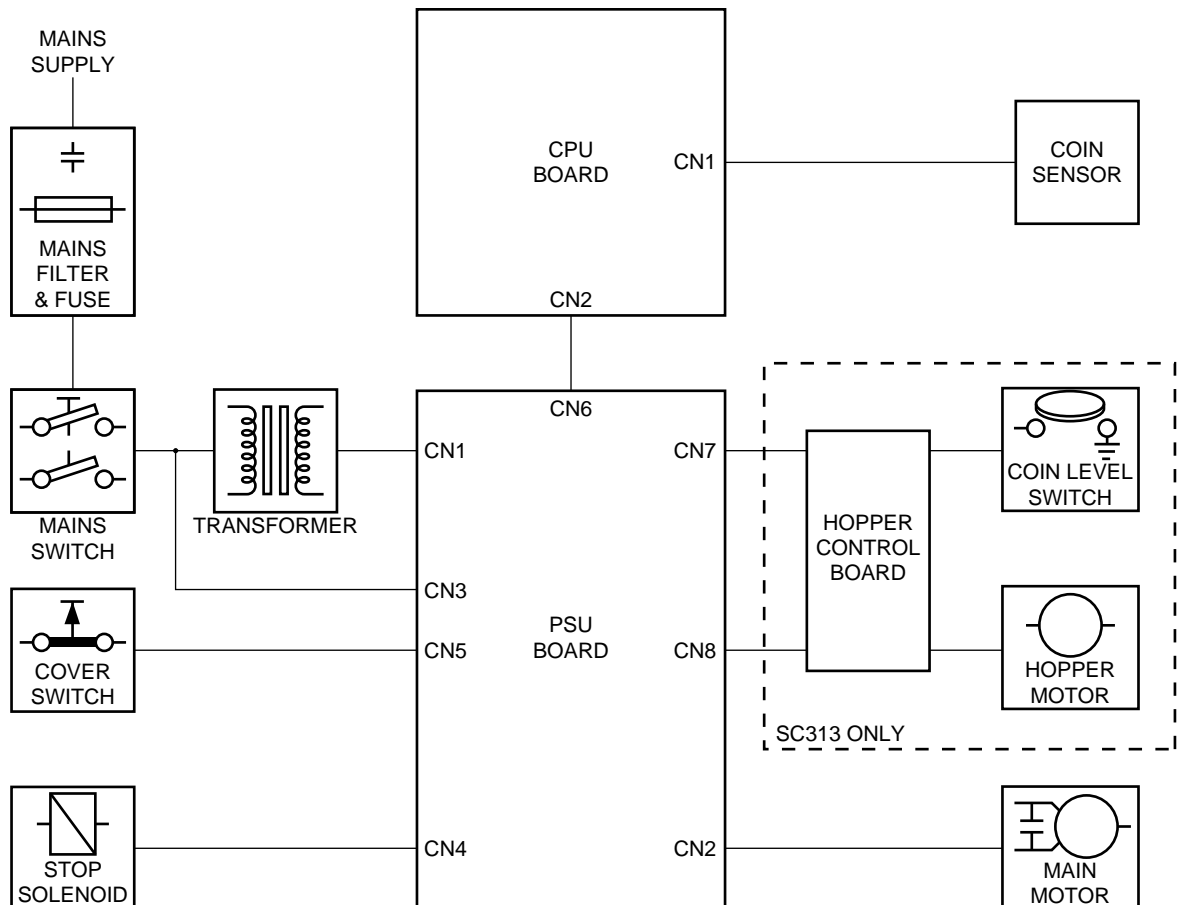

PSU board rev. 4

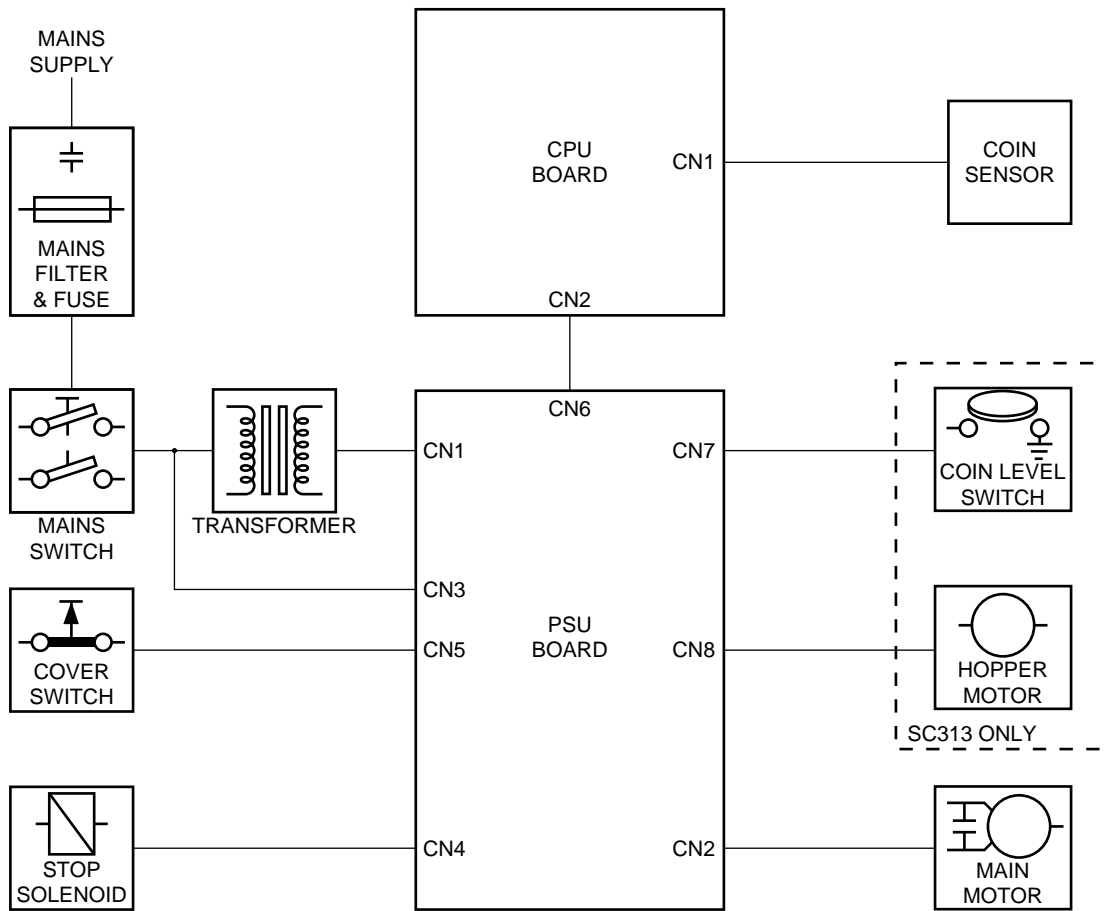

11.2 PSU Board Layout

PSU board rev. 2

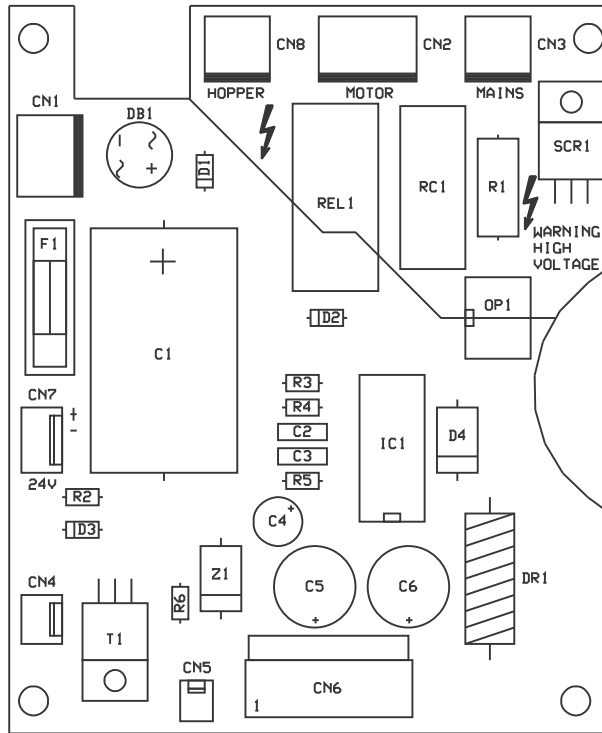

PSU board rev. 3

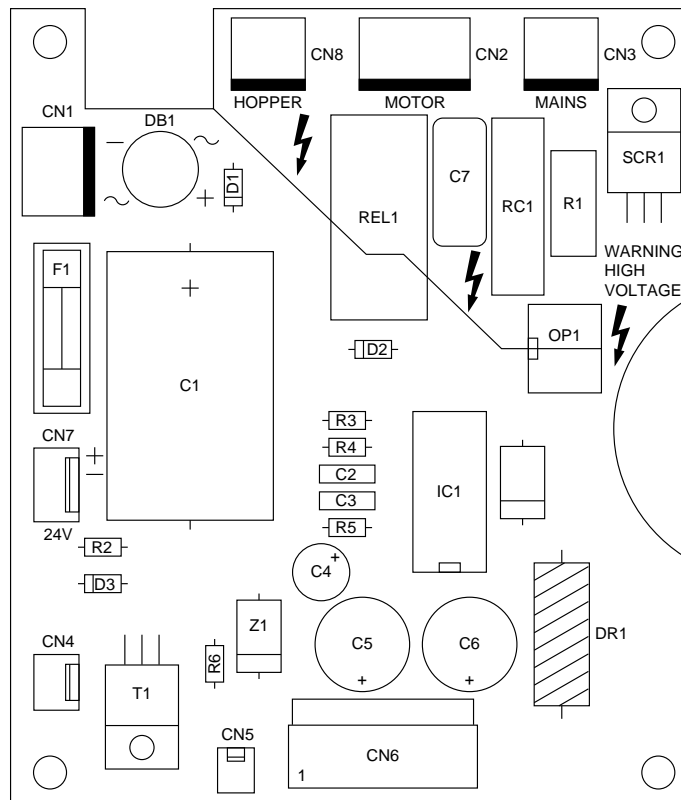

PSU board rev. 4

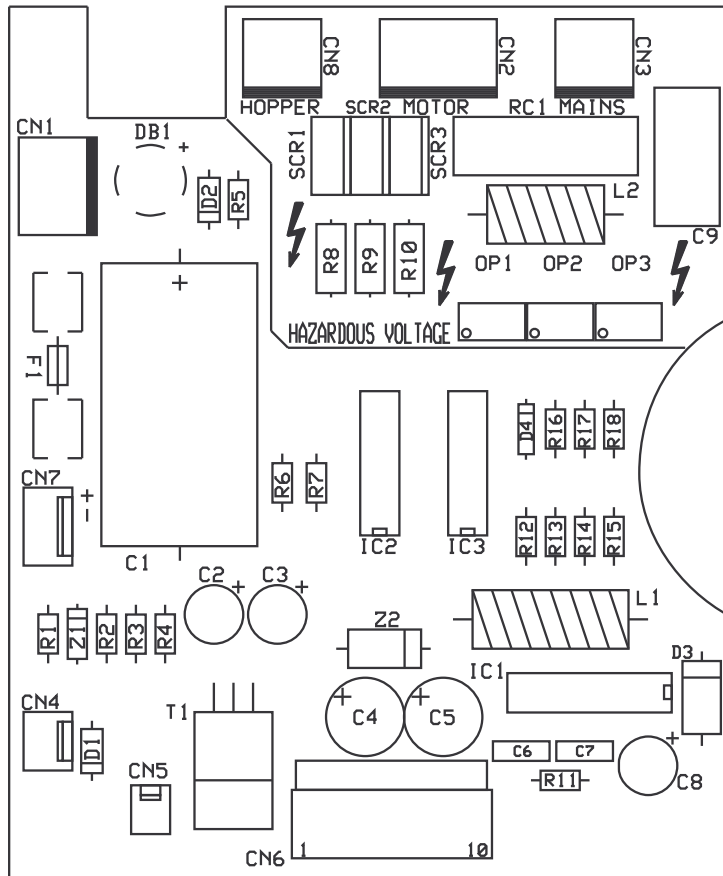

11.3 PSU Board Circuit Diagram

PSU board rev. 2

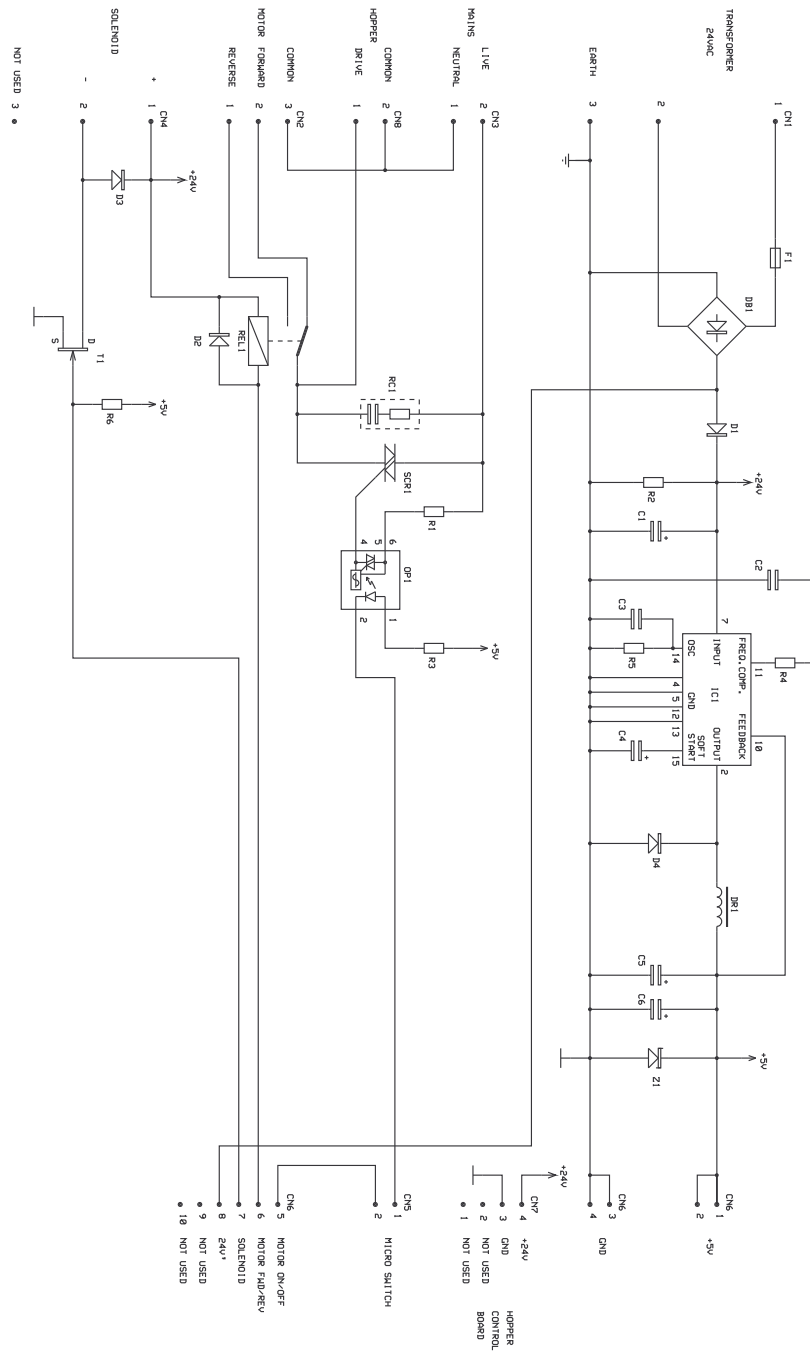

PSU board rev. 3

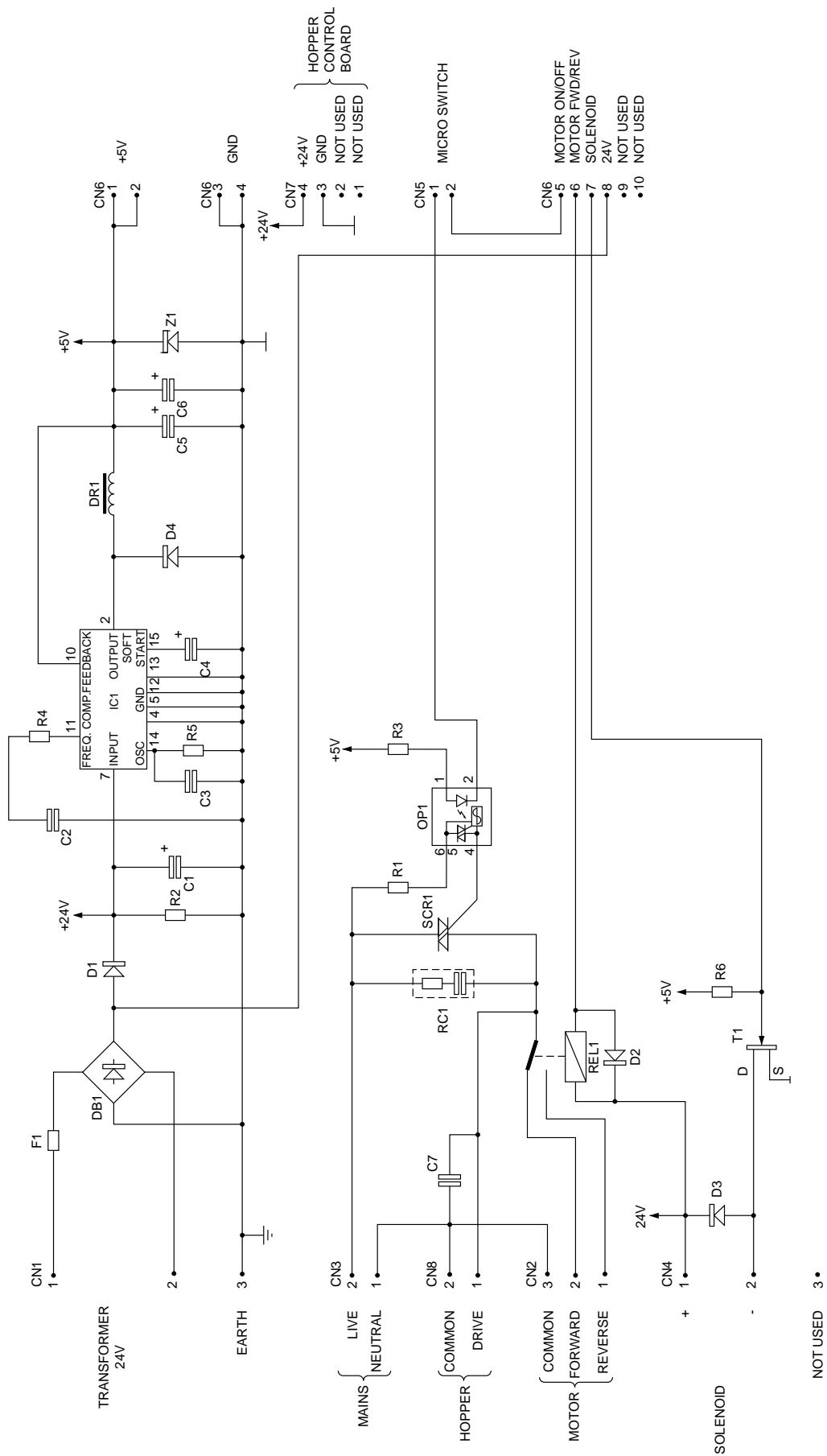

PSU board rev. 4

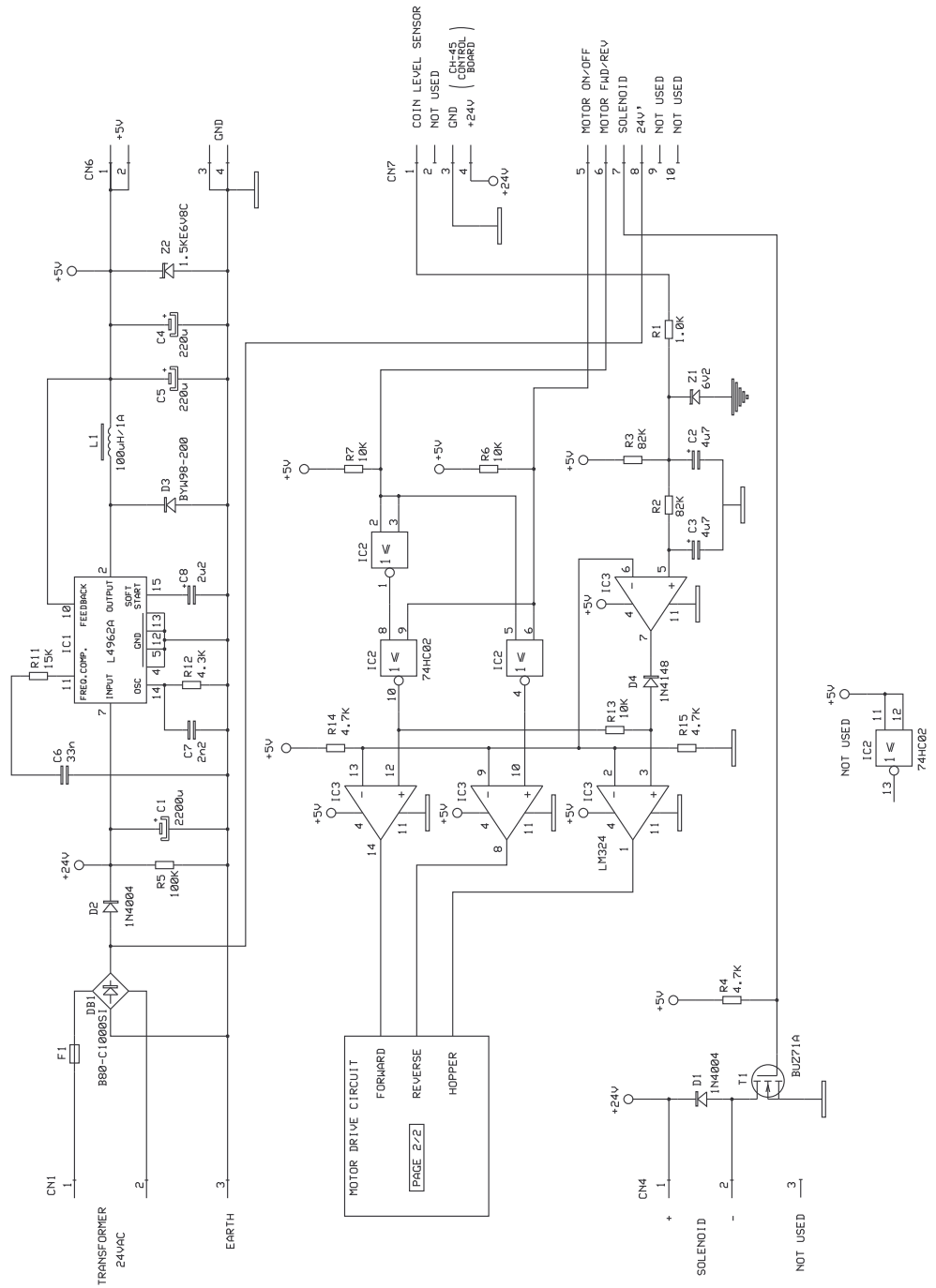

>>>

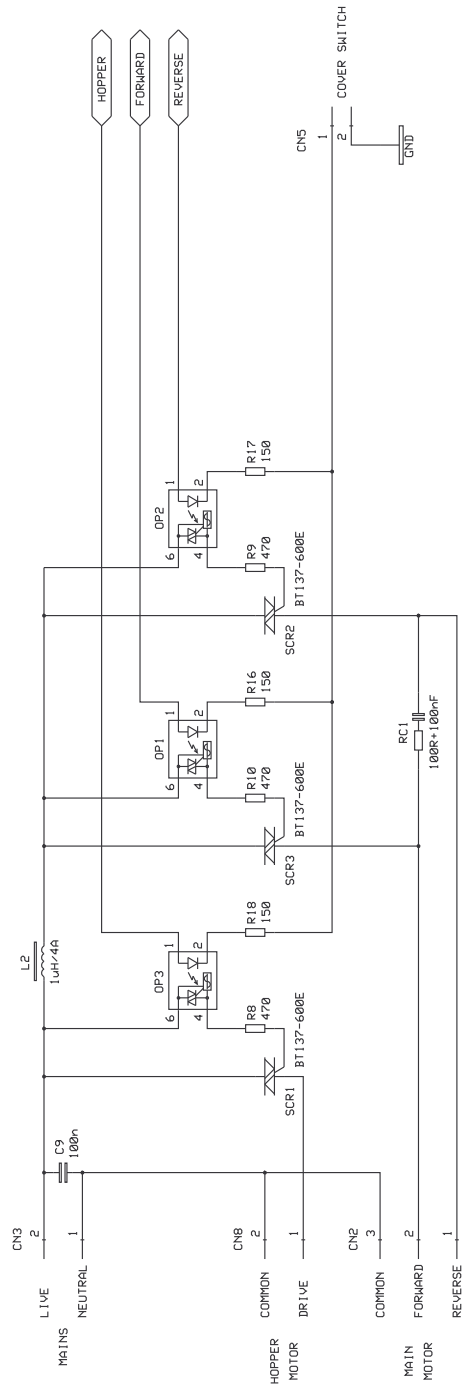

11.4 CPU Board Layout

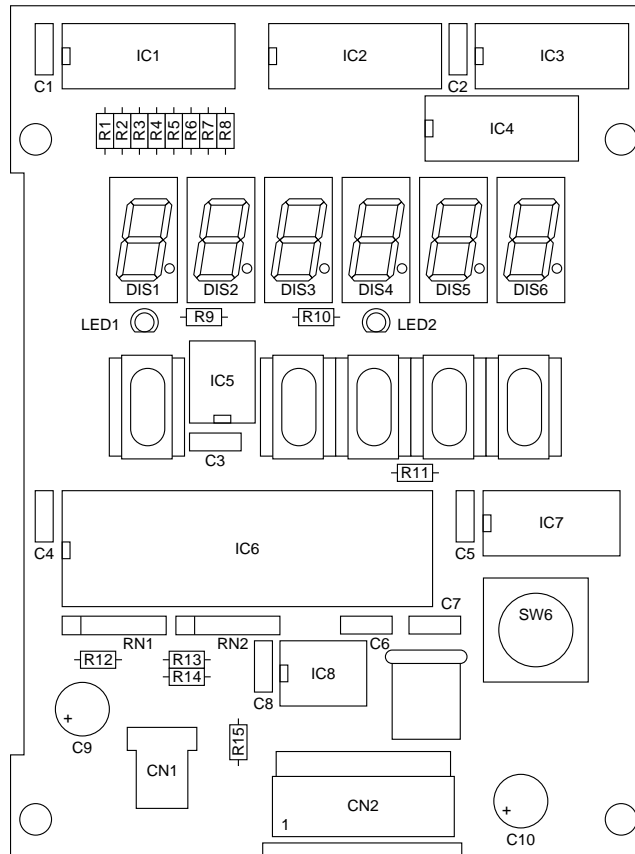

11.5 CPU Board Circuit Diagram

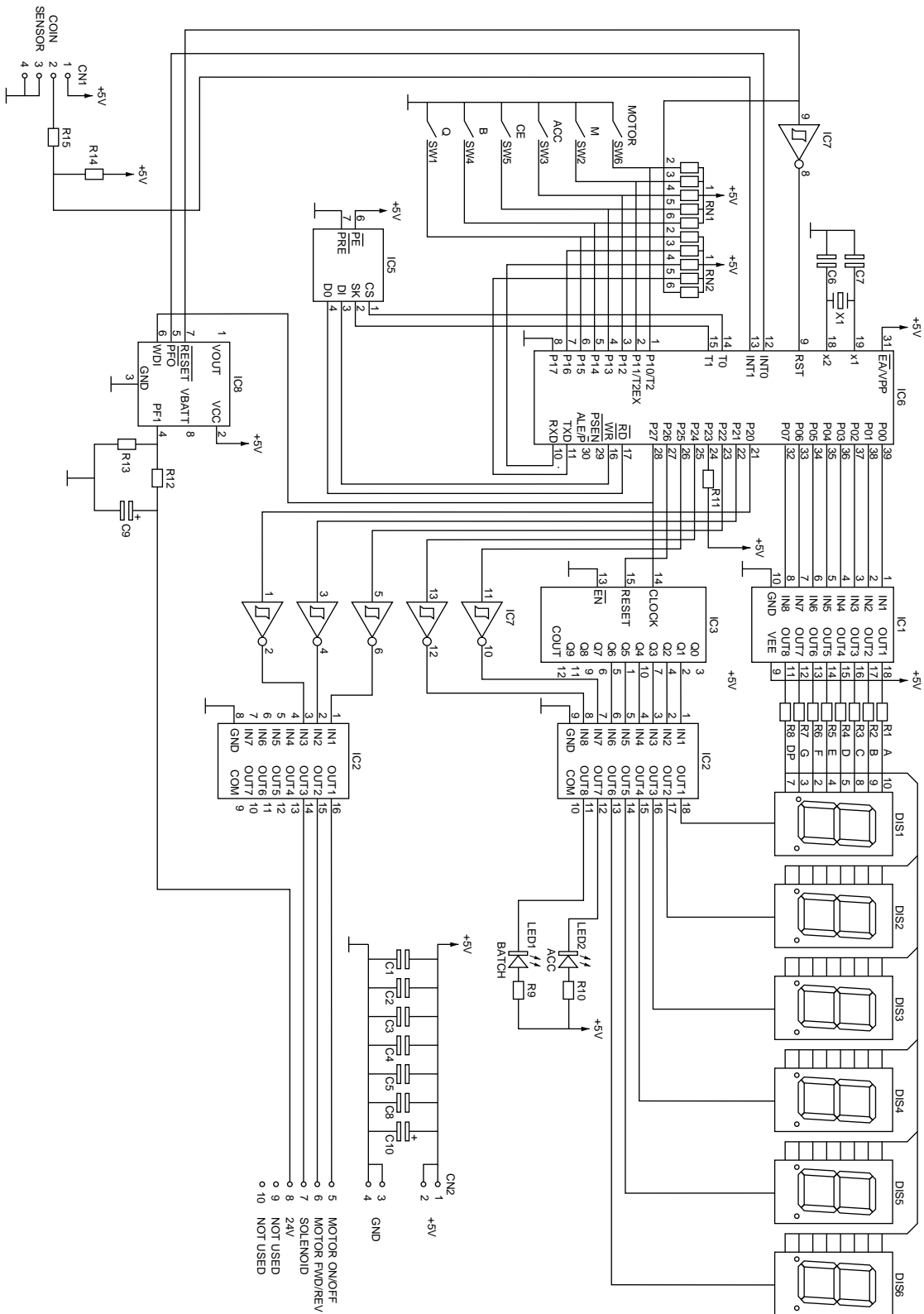

11.6 CH 45 Control PCB Layout

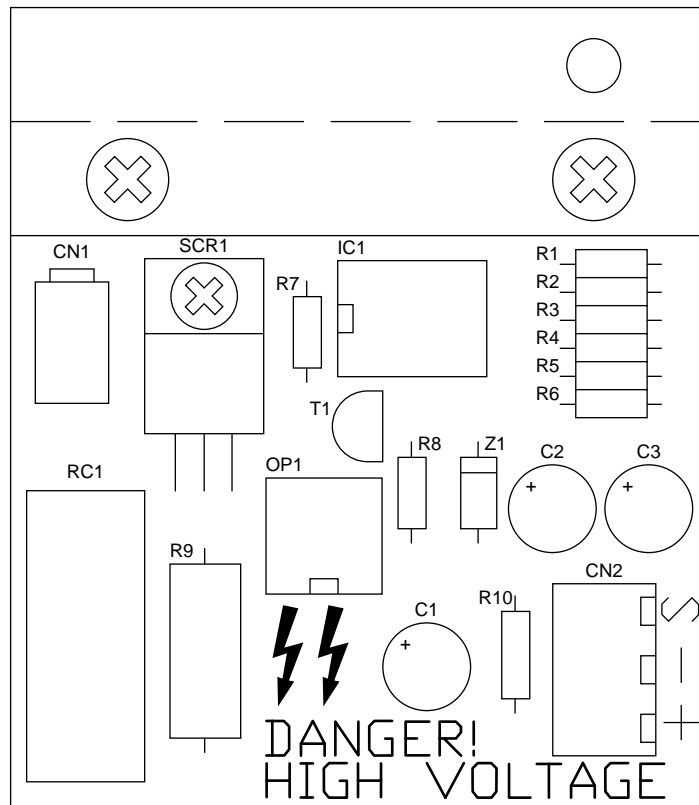

11.7 CH 45 Control PCB Circuit Diagram

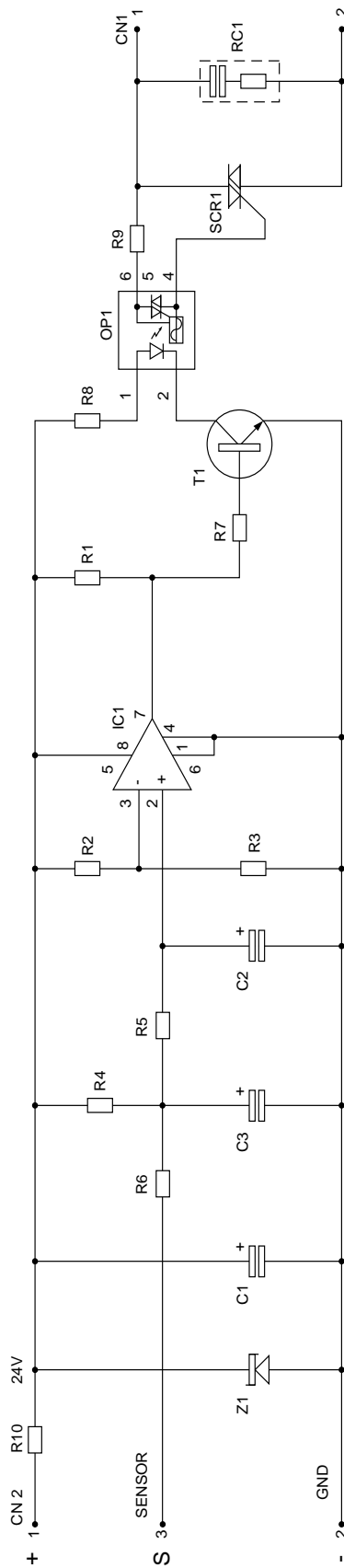

12 Spare Parts

12.1 Top Covers

Item	Description	Part No.	Remarks
1	Right hand slide	013297-000	
		013297-800	Light grey
2	Left hand slide	013296-000	
		013296-800	Light grey
3	Top cover	013279-000	
		013279-800	Including hinge, light grey
4	Left cover	013282-000	
		013282-800	Light grey
5	Diameter scale	013298-000	Standard
6	Right cover	013283-000	
		013283-800	Light grey
7	Thickness scale	013299-000	Standard
8	Rear cover	013280-000	
		013280-800	Light grey
-	Cover screw	023022-000	Not shown

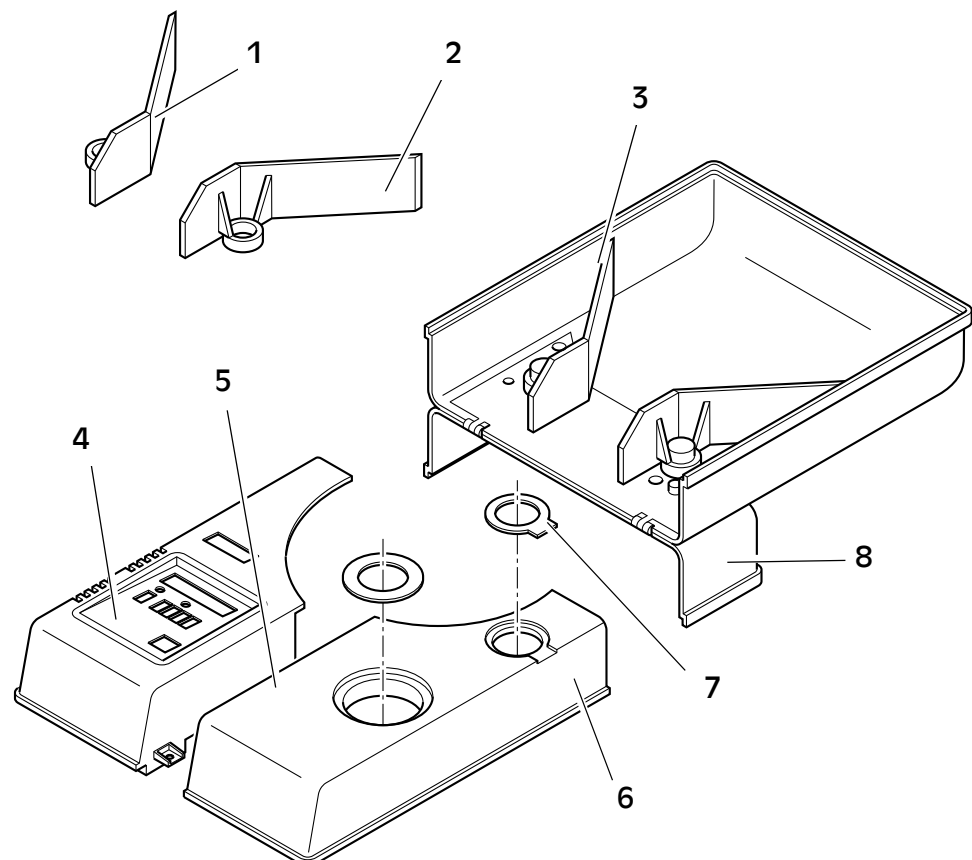

12.2 Bottom Cover Assembly

Item	Description	Part No.	Remarks
1	Bottom cover	013281-000	
		013281-800	Light grey
2	Power inlet	013492-000	
3	Handle	013278-000	
		013278-800	Light grey
4	Reject outlet plate complete	013471-000	
5	Outlet/bag holder	013300-000	
		013300-800	Light grey
6	Reject cup	013284-000	
		013284-800	Light grey
7	Side bag attachment BA3	011611-000	
	Side bag attachment BA3	011611-100	Grey
-	Rubber foot	013502-000	Not shown

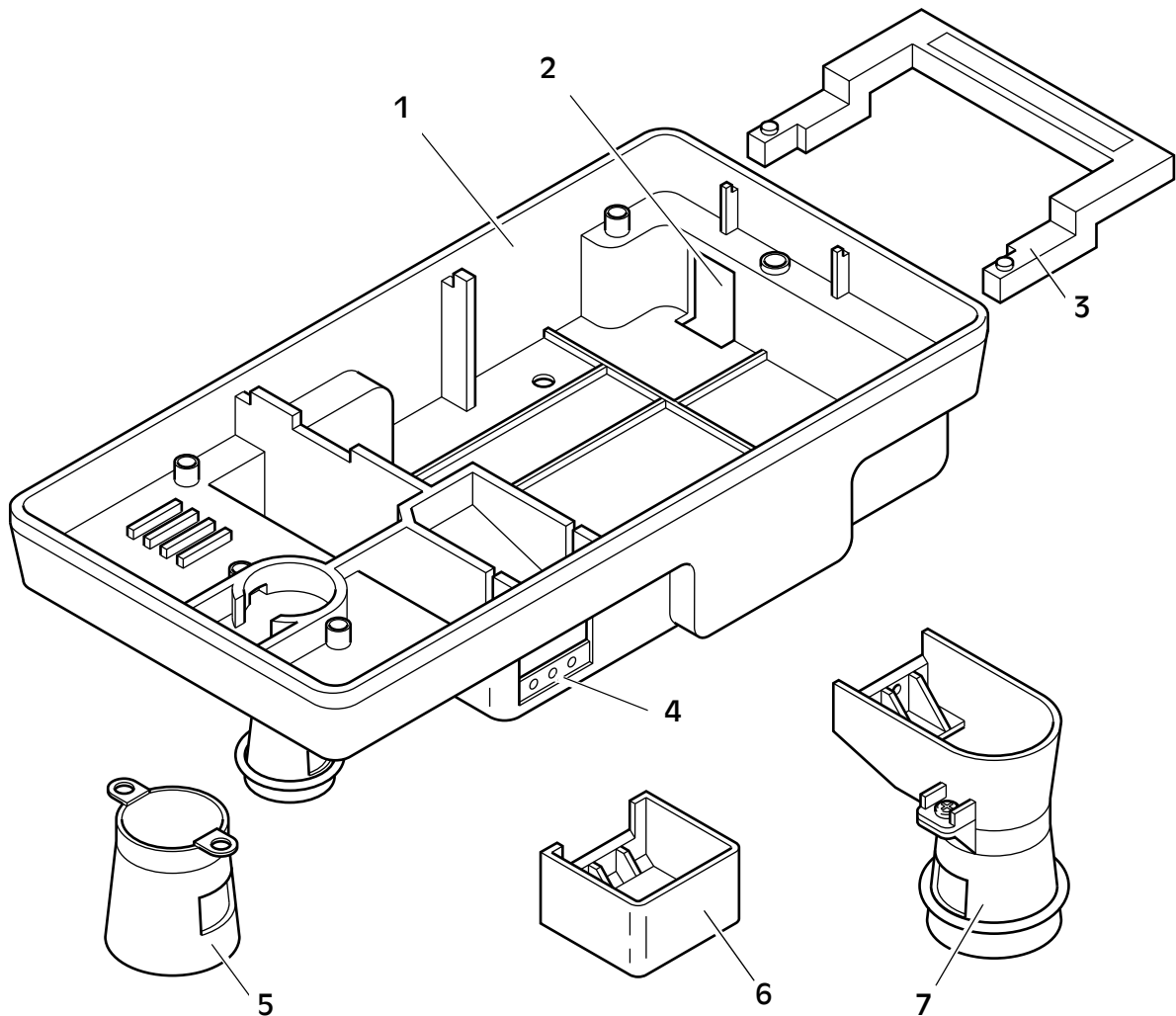

12.3 Motor Assembly

Item	Description	Part No.	Remarks
1	Transformer 220 V	013303-000	
	Transformer 120 V	013304-000	
2	Complete assembly 220 V	013301-000	
	Complete assembly 120 V	013302-000	
3	Motor 220 V	013273-000	
	Motor 120 V	013275-000	
4	Capacitor 4 μ F	013305-000	
	Capacitor 1.2 μ F	013306-000	
5	Idle wheel mechanism	013561-000	

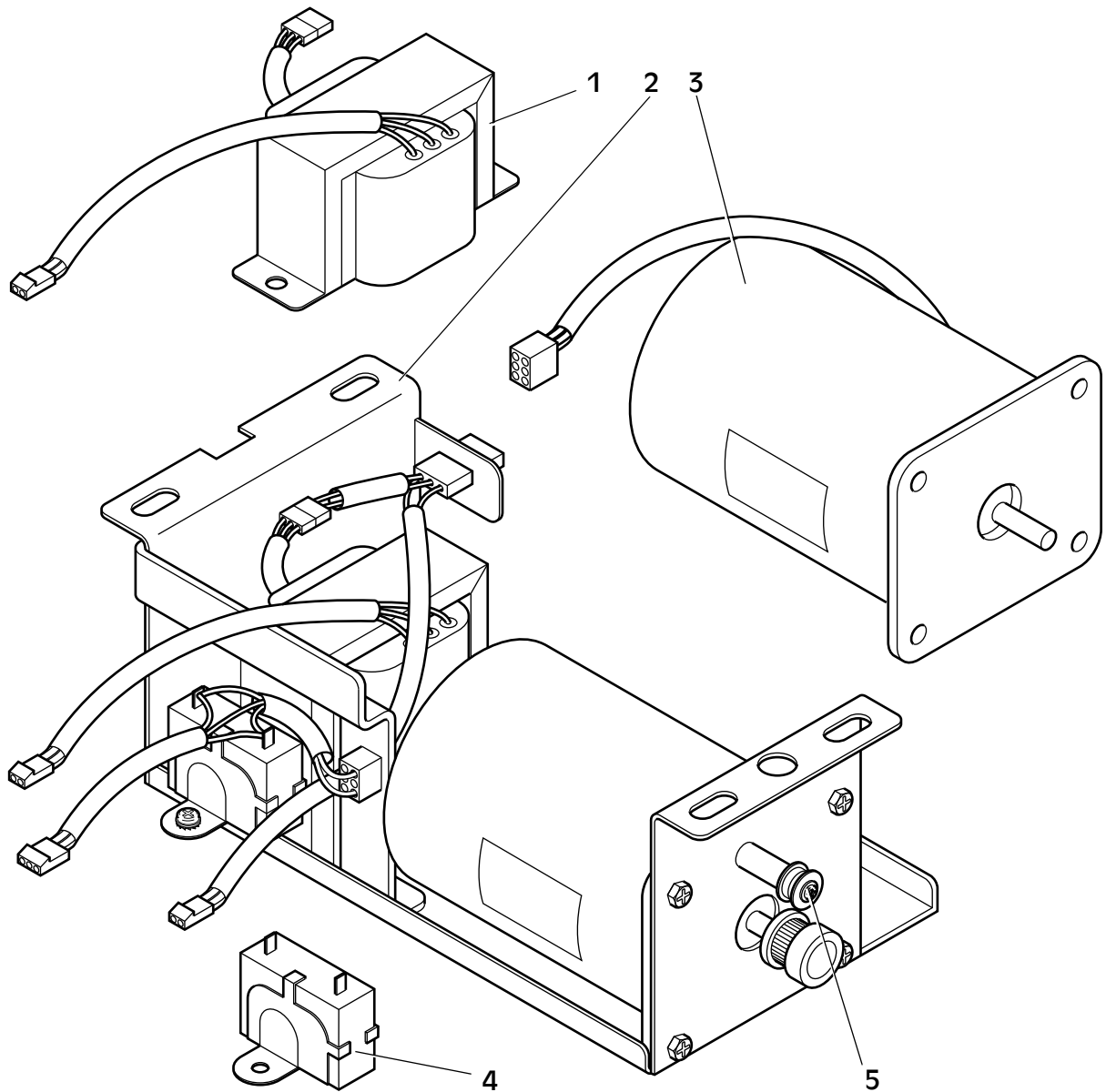

12.4 Main Plate Assembly

Item	Description	Part No.	Remarks
1	Left sorting guide 1.2 mm	013475-000	Standard
	Left sorting guide 2.2 mm	013475-001	
	Left sorting guide 1.0 mm	013475-002	
2	Diameter setting knob	013420-000	
3	Sensor	013450-000	
4	Spring for lever	023023-000	
5	Main plate assembly	013478-000	
6	Main plate only	013479-000	
7	Coin guide plate	013309-000	
8	Thickness block post assembly	013311-000	
9	Cam	013290-000	
10	Right sorting rail 1.2 mm	013289-000	Standard
	Right sorting rail 2.2 mm	013289-001	
	Right sorting rail 1.0 mm	013289-002	
11	Solenoid	013451-000	
12	Ratchet arm	013288-100	
13	Spring plunger	013560-000	
14	Solenoid arm	013566-000	

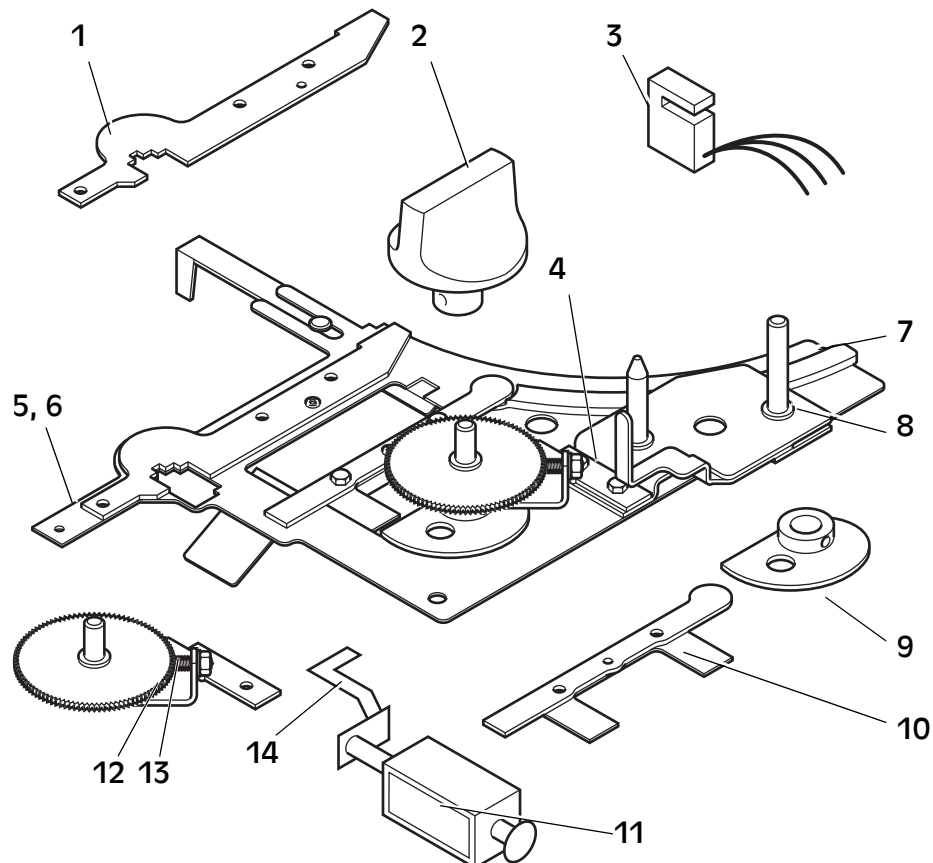

12.5 Thickness Guide Block

Item	Description	Part No.	Remarks
1	Thickness guide block	013272-000	
2	Thickness knob	013286-000	
3	Bottom plate	013312-000	

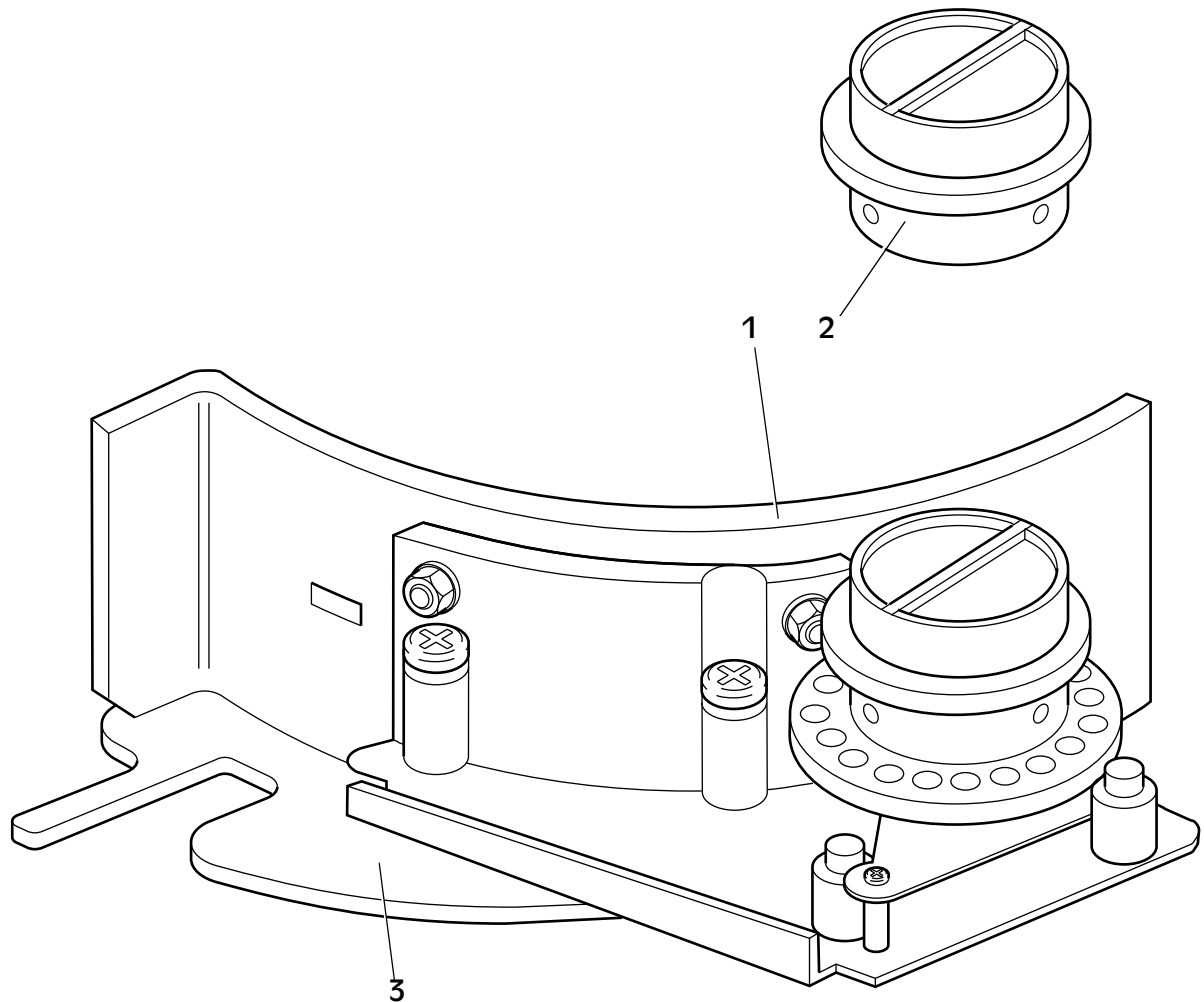

12.6 Feed Mechanism Assembly

Item	Description	Part No.	Remarks
1	Coin drive belt	013266-000	
2	Sorting chute	013293-000	
3	Pulley	013470-000	
4	Spring (pulley arm)	023007-000	
5	Feed mechanism assembly	013480-000	
6	Pulley top 220 V/50 Hz Pulley 120 V/60 Hz	013322-000 013323-000	
7	Channel drive belt	013267-000	
8	Spring	013449-000	

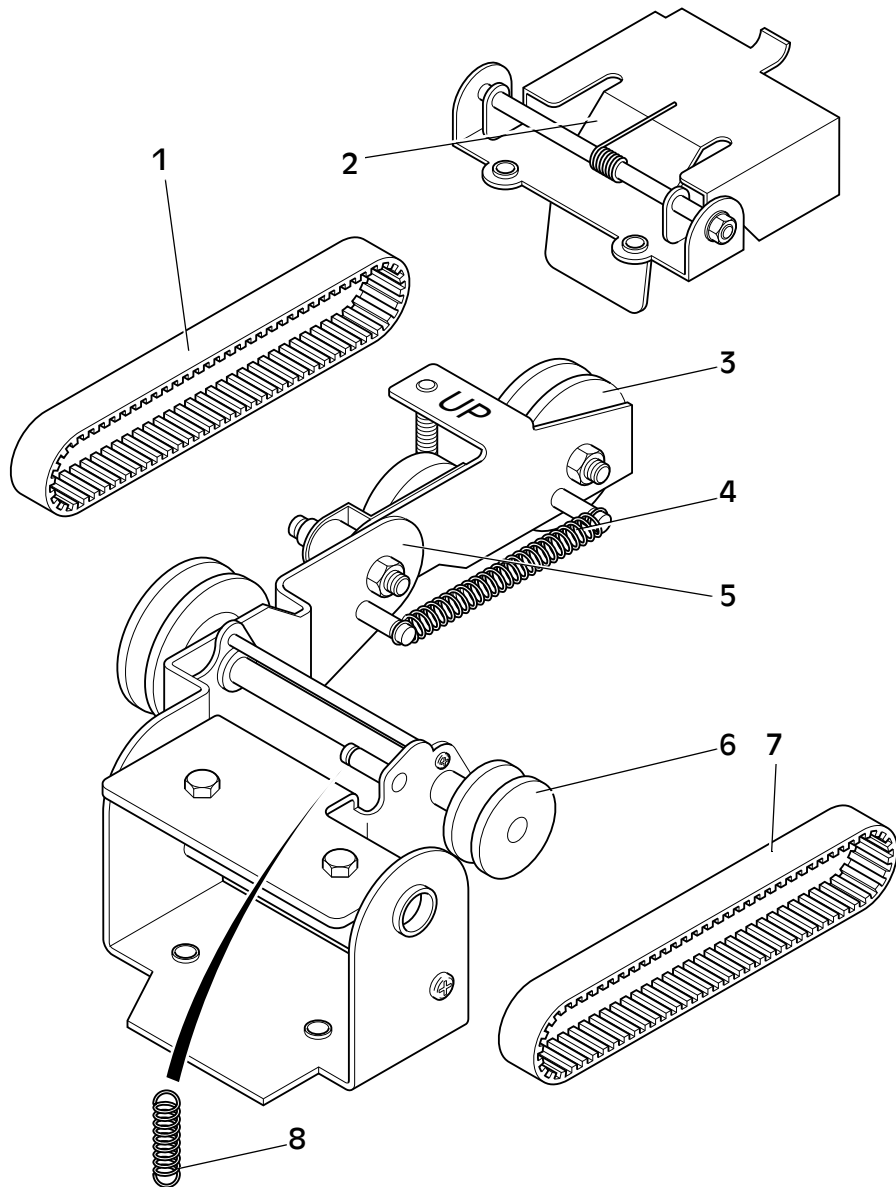

12.7 Drive Assembly

Item	Description	Part No.	Remarks
1	Cone kit	013324-000	
2	Nut for coin disc	013908-000	
3	Coin disc	013269-000	
4	Washer	013448-000	Coin disc thickness 0.1 mm
5	Main shaft	013326-000	
6	Steel border	013325-000	
7	Helical gear	013327-000	
8	Microswitch assembly kit	013294-000	
9	Drive assembly	013317-000	
10	Motor drive belt	013268-000	

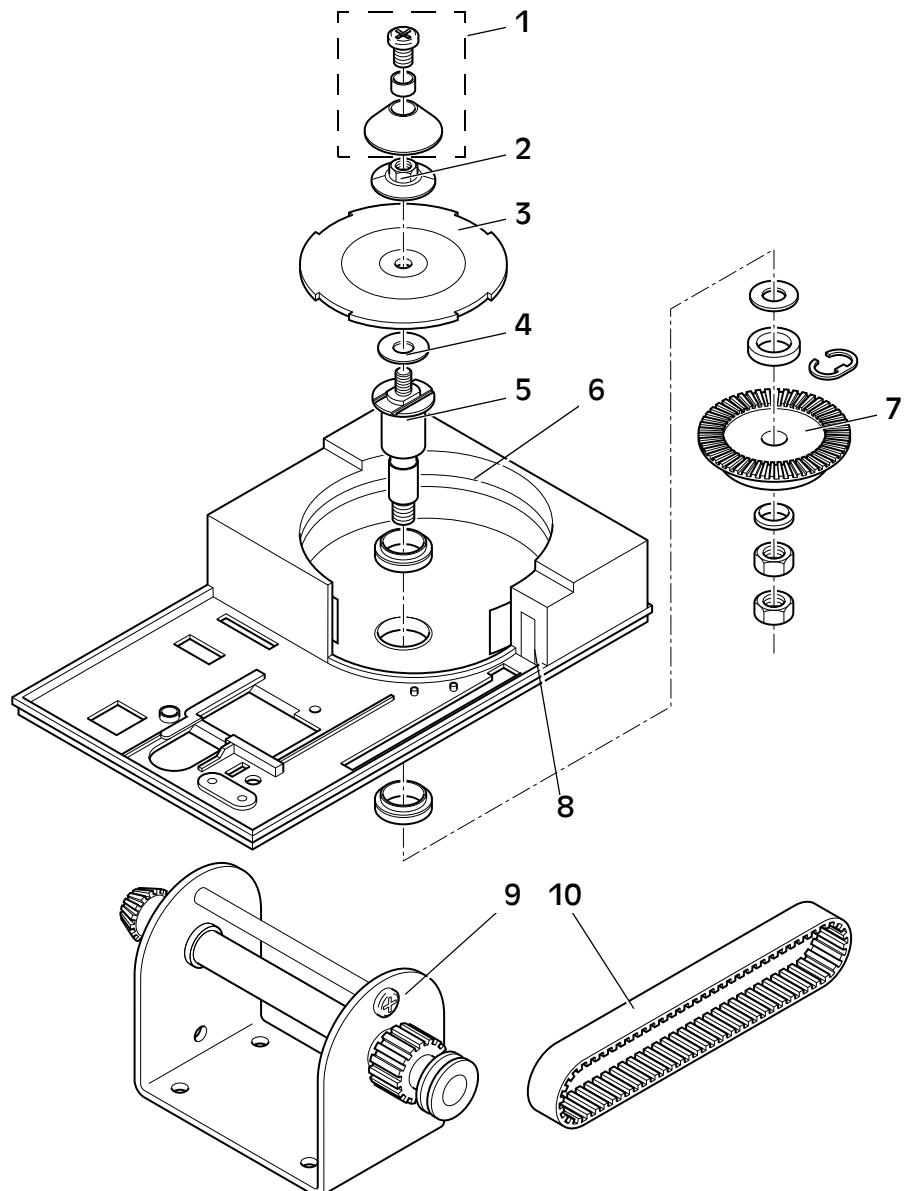

12.8 Electronics

Item	Description	Part No.	Remarks
1	PSU board complete	011570-001	Note if PSU board 011570-000 is replaced by 011570-001 the CPU board and ribbon cable also has to be replaced, see service information 3x3-001 for more information
2	Relay (PSU rev 1)	013319-000	See overleaf.
3	Relay G2R-1 24VDC Omron	013319-001	See overleaf.
4	CPU complete	023133-001	Note if CPU board 023133-000 is replaced by 023133-001 the PSU board and ribbon cable also has to be replaced, see service information 3x3-001 for more information
		023133-002	For light grey covers with 7-segments display.
5	Display 7 segments	013477-000	
6	Switch with red top	013318-000	
7	Switch with yellow top	013320-000	
8	Standard microprocessor	011593-xxx	
9	Start switch	004257-000	
10	Top	004257-015	
-	Ribbon cable	013321-000	Not shown, intended for CPU board 023133-000 and PSU board 011570-000 in SC 303/313 with dark grey cover
-	Ribbon cable	013321-001	Not shown, intended for CPU board 023133-001 and PSU board 011570-001 in SC 303/313 with dark grey cover
-	Ribbon cable	013321-002	Not shown, intended for CPU board 023133-002 and PSU board 011570-002. for SC 303/313 with 7-segments display.

Note! The CPU board does **not** include the microprocessor, which must be ordered separately.

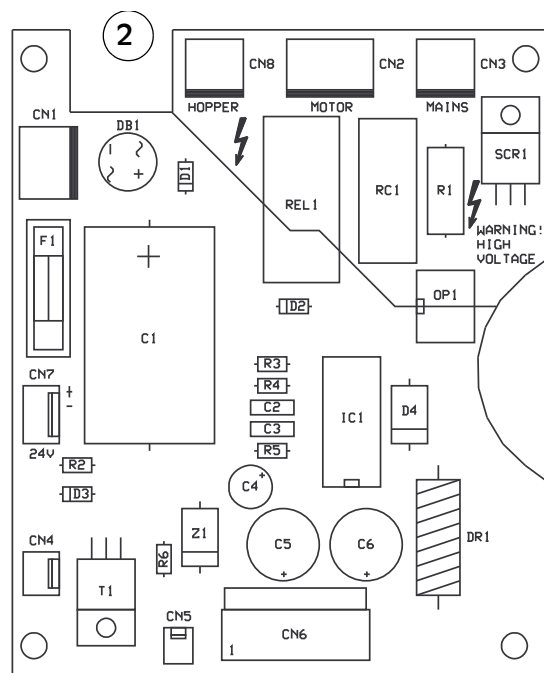
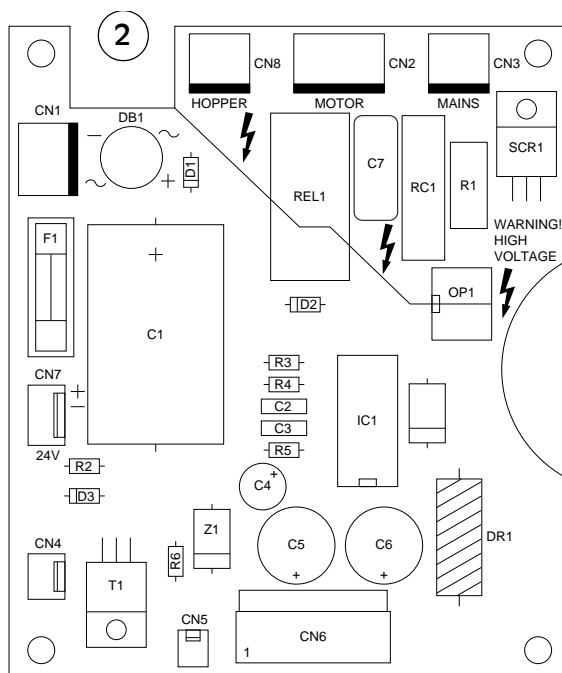
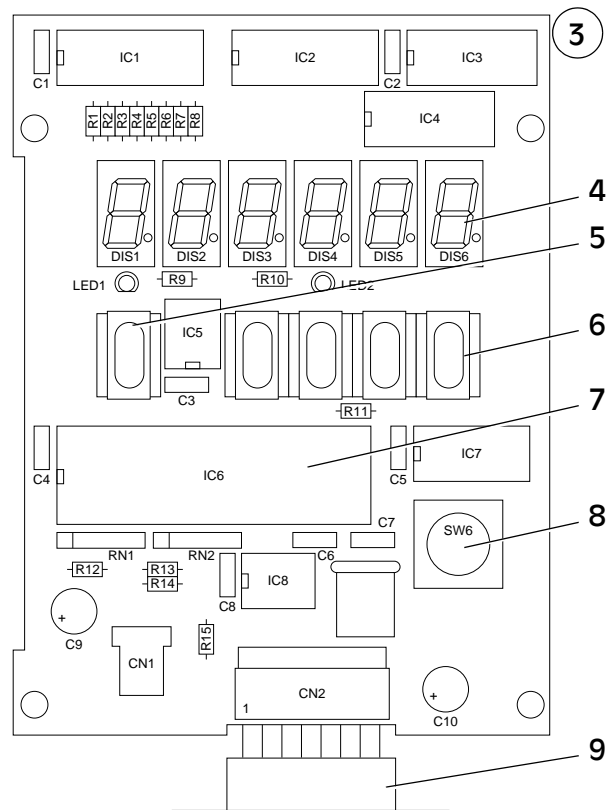
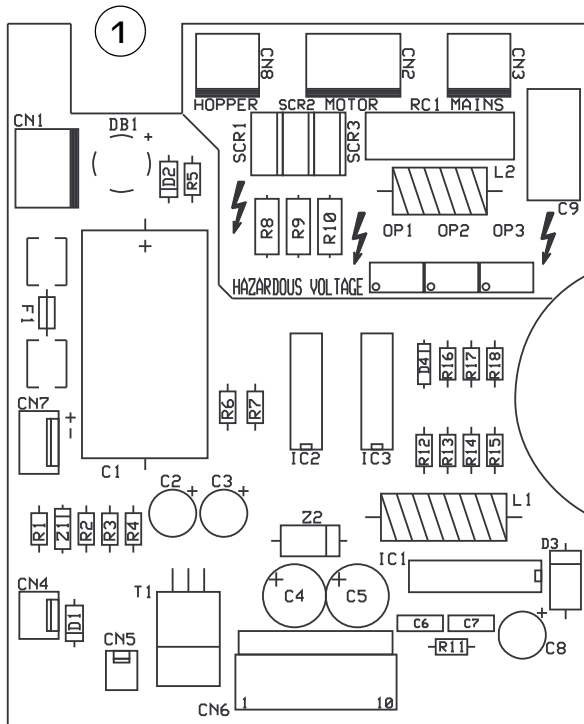

12.9 SC 313 Hopper Unit

Item	Description	Part No.	Remarks
1	Main plate complete	013587-000	
2	Motor 110/220 V	013458-000	
3	Coin level sensor	013464-000	
-	Cover, hopper SC 313	013465-800	Light grey Not shown

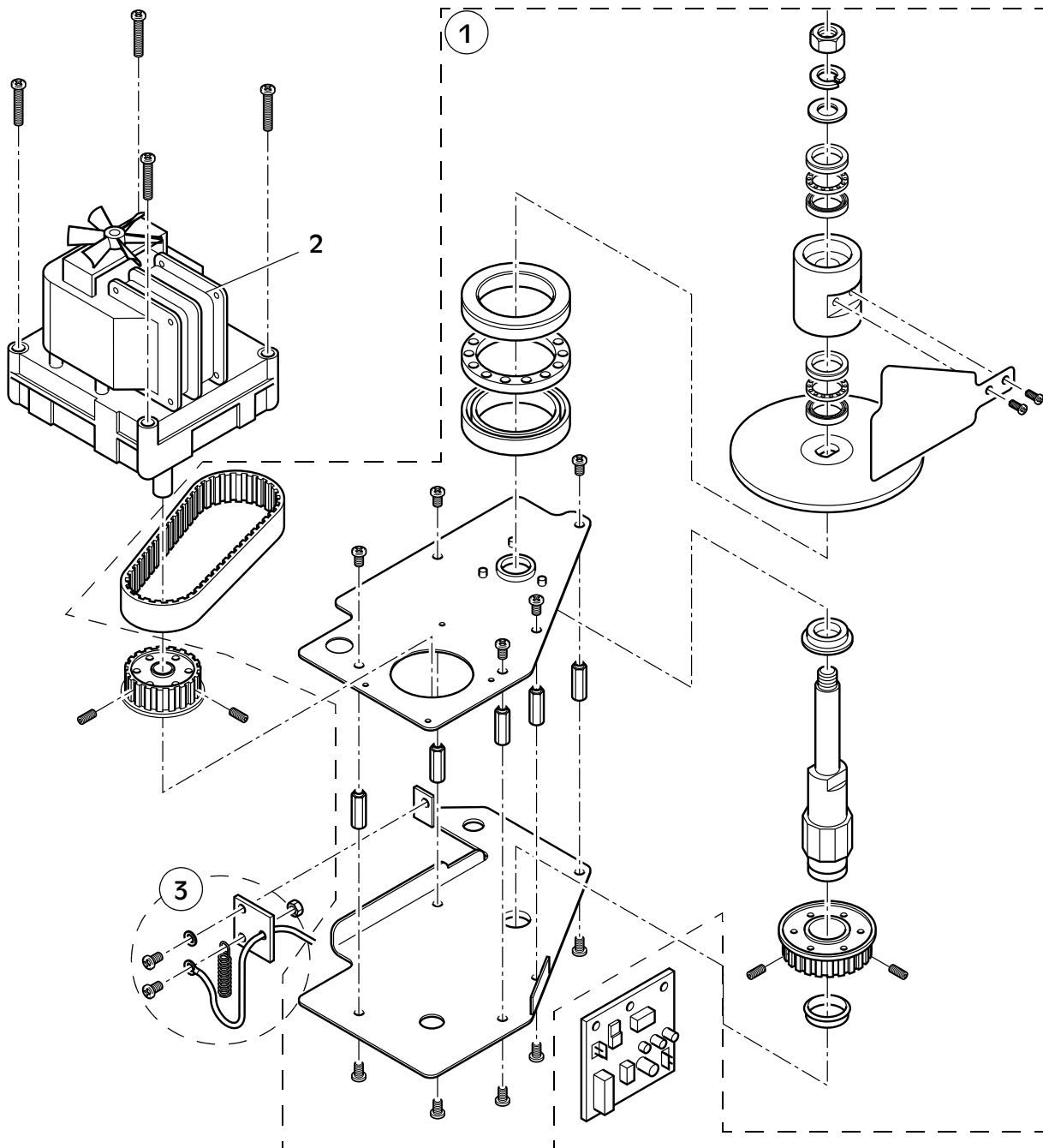



SCAN COIN AB
Jägershillgatan 26
SE-213 75 Malmö, Sweden
Operator +46 40 600 06 00
Fax +46 40 600 07 00
info@scancoin.se
www.scancoin.com